

MYERS® MRG20 SERIES

The Myers® MRG20 series grinder pumps are rugged-built cast iron, yet offer an economical choice for residential applications. The patented cutter mechanism effectively reduces sewage solids into fine slurry. Heavy-duty 2HP motor, rugged cast iron construction and simple operation with tethered automatic switch – control panel not required.

APPLICATIONS

Sewage grinding, effluent and wastewater removal

SPECIFICATIONS

Shut-off Head – 105' (32 m)
Liquids Handling – Raw sewage
Intermittent Liquid Temperature – Up to 140°F (60°C)
Winding – 311°F (155°C)
Motor/Electrical Data – 2 HP, 3450 RPM, 1Ø, capacitor start/run 230V; 60Hz, 15A
Acceptable pH Range – 6-9
Discharge, NPT – 1-1/4" (31.75 mm)
Sump Diameter Duplex – 36" (91.4 cm)
Motor Housing – Cast iron
Impeller – Eng. thermoplastic
Power Cord – 20'
Shaft Seal – Carbon and ceramic; or tungsten carbide (optional)
Pump, Motor Shaft – Stainless steel (416 SS)
Minimum Sump Diameter –
 Simplex: 24" (61.0 cm)
 Duplex: 36" (91.4 cm)



FEATURES

Leak Protection

Long-life silicon carbide or carbon ceramic seal protects motor against water leakage

Easy Starting

High-torque capacitor starts easily under heavy loads – no external capacitor needed

Non-clog Design

Patented cutter mechanism and recessed impeller design effectively reduces typical sewage solids to a fine slurry

Runs Cooler

Oil-filled motor provides continuous bearing lubrication and maximizes heat dissipation

Free-flow Design

Recessed impeller design improves the free flow of solids and reduces bearing load for longer service life

Thermal Overload

Heat sensor overload protection with automatic reset when motor cools to a safe operating temperature

Stainless Steel Strong

Pump shaft and all fasteners constructed of stainless steel for superior corrosion resistance

MYERS® MRG20 SERIES

ORDERING INFORMATION

| Catalog Number | HP | Volts | Phase/Cycles | Amps | Discharge Size | Switch Type | Approx. Cord Length | Wt. Lbs. |
|----------------|----|-------|--------------|------|----------------|---------------------|---------------------|----------|
| MRG20-21 | 2 | 230 | 1/60 | 15.0 | 1-1/4" | Manual | 20' | 83 |
| MRG20-21A | 2 | 230 | 1/60 | 15.0 | 1-1/4" | Tethered Automatic* | 20' | 85 |
| MRG20-21K | 2 | 230 | 1/60 | 15.0 | 1-1/4" | Manual | 20' | 85 |
| MRG20-21AK | 2 | 230 | 1/60 | 15.0 | 1-1/4" | Tethered Automatic* | 20' | 87 |

*Piggyback

MOTOR ELECTRICAL DATA

| Model | HP | Volts | Phase | Start Amps | Run Amps | Run KW | Start KVA | Run KVA | NEC Code Letter | Service Factor |
|--------|----|-------|-------|------------|----------|--------|-----------|---------|-----------------|----------------|
| MRG20 | 2 | 230 | 1 | 51.9 | 15.0 | 2.9 | 11.9 | 3.5 | G | 1.25 |
| MRG20A | 2 | 230 | 1 | 51.9 | 15.0 | 2.9 | 11.9 | 3.5 | G | 1.25 |

DIMENSIONS

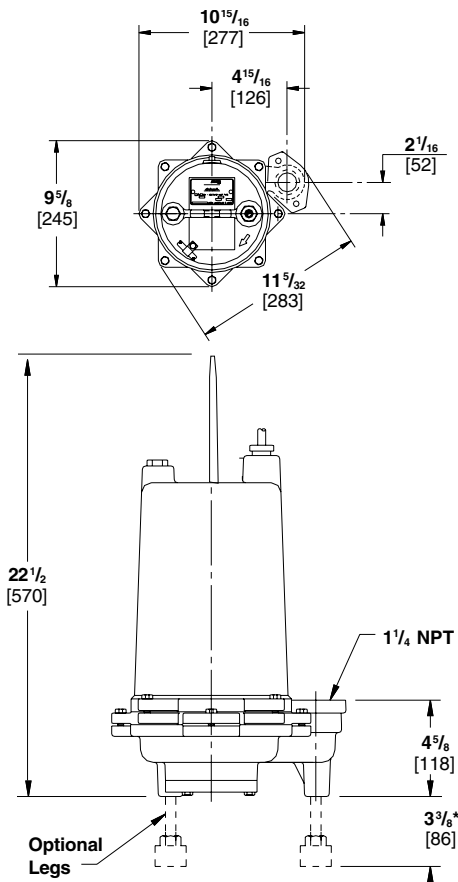

*Leg kit required when not using guide rail lift-out system.

PUMP PERFORMANCE

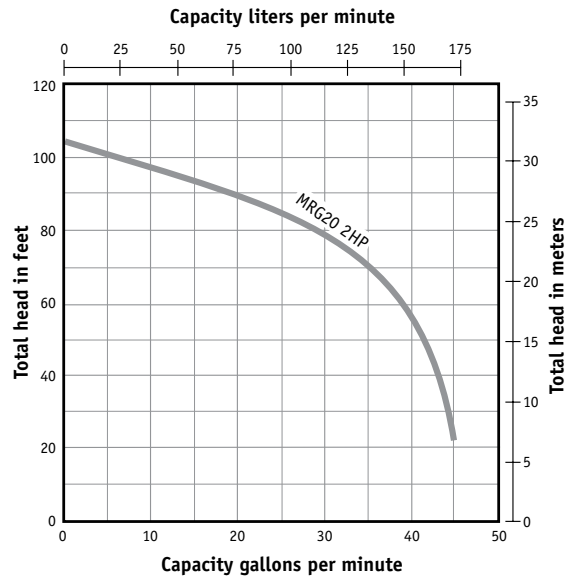

MYERS® MRG20 SERIES

SPECIFICATIONS

Inside Packages

Simplex 30" x 36" includes:

- MRG20 2 HP grinder pump 230V, 1Ø
- 30" x 36" FRP basin
- Steel cover
- Check valve
- Two SDR-35 inlet hubs and Sch. 40 adapters
- Wide angle on/off float switch and a mercury alarm float switch

Outside Packages

Simplex 24" includes:

- MRG20 2 HP grinder pump 230V, 1Ø
- Basin, FRP 24" x 5'
24" x 6'
24" x 7'
24" x 8'
- Polypropylene cover
- NEMA 4X junction box
- Two SDR-35 inlet hubs and Sch. 40 adapters
- Quick-disconnect rail system with stainless steel rails, check valve and ball valve
- Wide angle on/off float switch and a mercury alarm float switch

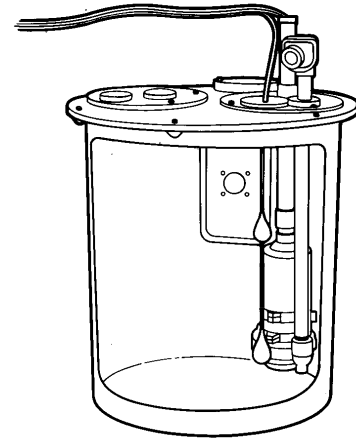

Inside Package

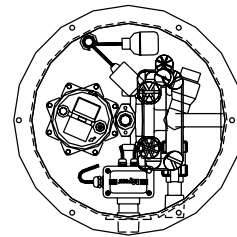

Outside Package

FEATURES

Everything is Included

Completely pre-engineered, pre-packaged, pre-assembled* systems ready for installation. Eliminate guesswork of selecting components – no mismatched or improperly fitting parts.

Easy Installation

Installer only has to excavate, secure, connect discharge lines, locate and mount inlet hub, locate and mount panel, install pump in basin and connect electrical wiring.

*Pump and inlet hub shipped separately – must be field installed. Wiring connections to be made by qualified electrician.

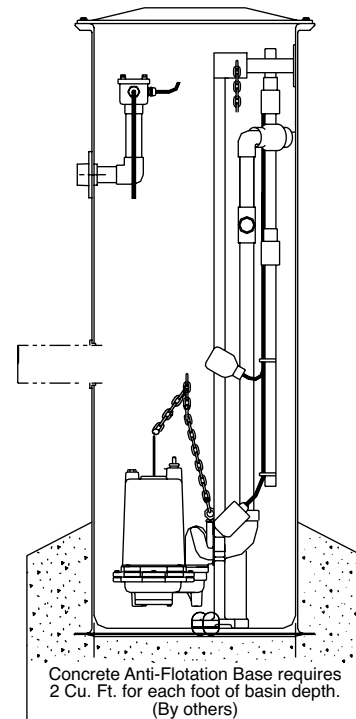

Concrete Anti-Flotation Base requires 2 Cu. Ft. for each foot of basin depth. (By others)

MYERS[®] MRG20 SERIES

SPECIFICATIONS

Pump Model – Pump shall be of the centrifugal type, Myers model MRG20 Series, with an integrally built-in grinder unit and submersible type motor. The grinder unit shall be capable of macerating all material in normal domestic and commercial sewage, including reasonable amounts of foreign objects such as small wood, sticks, plastic, thin rubber, sanitary napkins, disposable diapers and the like, to a fine slurry that will pass freely through the pump and 1¼" discharge pipe. Discharge shall be 1¼" NPT.

Operating Conditions – Pump shall have a capacity of _____ GPM at a total head of _____ feet and shall use a 2 hp motor operating at 3450 RPM.

Motor – Pump motor shall be of the submersible type rated 2 hp at 3450 RPM. Motor shall be for 60 Hz, single phase, 230 volts. Motor shall be capacitor start, capacitor run type for high starting torque.

Stator winding shall be of the open type with Class F insulation, good for 155° C (311° F) maximum operating temperature. Winding housing shall be filled with a clean, high dielectric oil that lubricates bearings and seals and transfers heat from windings and rotor to outer shell. Air-filled motors which do not have the superior heat dissipating capabilities of oil-filled motors shall not be considered equal.

Motor shall have two heavy-duty ball bearings to support pump shaft and take radial and thrust loads. Ball bearings shall be designed for 50,000 hours B-10 life. Stator shall be bolted to seal plate for easy motor replacement.

The motor shall have a heat sensor thermostat and overload attached to the top end of the motor windings to stop the motor if the motor winding temperature reaches 284° F. The high temperature shutoff will cause the pump to cease operation, should a control failure cause the pump to run in a dry wet well. The thermostat shall reset automatically when the motor cools to a safe operating temperature.

The common motor pump and grinder shaft shall be of #416 stainless steel threaded to take pump impeller and grinder impeller.

Seals – Motor shall be protected by one rotary mechanical seal. Seal face shall be carbon and ceramic and lapped to a flatness of three light bands. Optional tungsten and carbonate.

Pump Impeller – The pump impeller shall be of the recessed Myers type to provide an open unobstructed passage through the volute for the ground solids. Impeller shall be engineered thermoplastic and threaded onto stainless steel shaft.

Grinder Construction – Grinder assembly shall consist of grinder impeller and shredding ring and shall be mounted directly below the volute passage. Grinder impeller to be threaded onto stainless shaft and shall be locked with screw and washer. The shredding ring shall be pressed into an iron holding flange for easy removal. The flange shall be provided with tapped back-off holes so that screws can be used to push the shredding ring from housing.

All grinding of solids shall be from action of the impeller against the shredding ring.

Both grinder impellers and shredding ring shall be of 440C stainless steel hardened to 58-60 Rockwell C.

Corrosion Protection – All iron castings shall be pre-treated with phosphate and chromic rinse and to be painted before machining, and all machined surfaces exposed to the sewage water to be re-painted. All fasteners to be 300 series stainless steel.

Power Cord – The motor power cord shall be 14 GA AWG (3 PHASE) OR 166A AWG (1 PHASE). The cable jacket shall be sealed at the motor entrance by means of a rubber compression washer and compression nut. A heat shrink tube filled with epoxy shall seal the outer cable jacket and the individual leads to prevent water from entering the motor housing.

Level Control – An automatic control is provided by a heavy-duty float switch tethered to the side of the pump, having a piggyback plug on one end. This piggyback float switch operates the pump directly without need of control panel.



USA
293 WRIGHT STREET, DELAVAN, WI 53115 WWW.FEMEYERS.COM
PH: 888-987-8677 ORDERS FAX: 800-426-9446

CANADA
269 TRILLIUM DRIVE, KITCHENER, ONTARIO, CANADA N2G 4W5
PH: 519-606-5484 ORDERS FAX: 800-426-9446

Because we are continuously improving our products and services, Pentair reserves the right to change specifications without prior notice.