

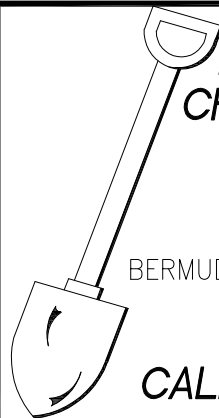

MINISTRY OF PUBLIC WORKS AND ENGINEERING
DEPARTMENT OF WORKS AND ENGINEERING

WATFORD BRIDGE
WATERPROOFING AND EXPANSION JOINT REPLACEMENT



BEFORE YOU DIG
CHECK WHAT'S BELOW

BELCO: 299-2800
 TELCO: 295-1001
 W&E WATER: 297-7637
 BERMUDA WATER WORKS: 236-1288
 CABLE VISION: 292-5544

CALL ONE WEEK AHEAD

THE MINISTRY OF
 PUBLIC WORKS

P.O. Box HM525 Hamilton HMCX Bermuda
 Phone: (441)295-5151

DEPARTMENT OF
 WORKS AND ENGINEERING
 Fax: (441)294-9087

Structures Section

NOTE

1. ORIGINAL PAPER SIZE OF DRAWING IS 34"x22".
 ALL SCALES SHOWN ARE TO BE HALVED WHEN
 DRAWING IS PRINTED ON 17"x11" PAPER.

DRAWINGS:

S-0 COVER
 S-1 AREA OF WORKS
 S-2 BRIDGE JOINT DETAILS

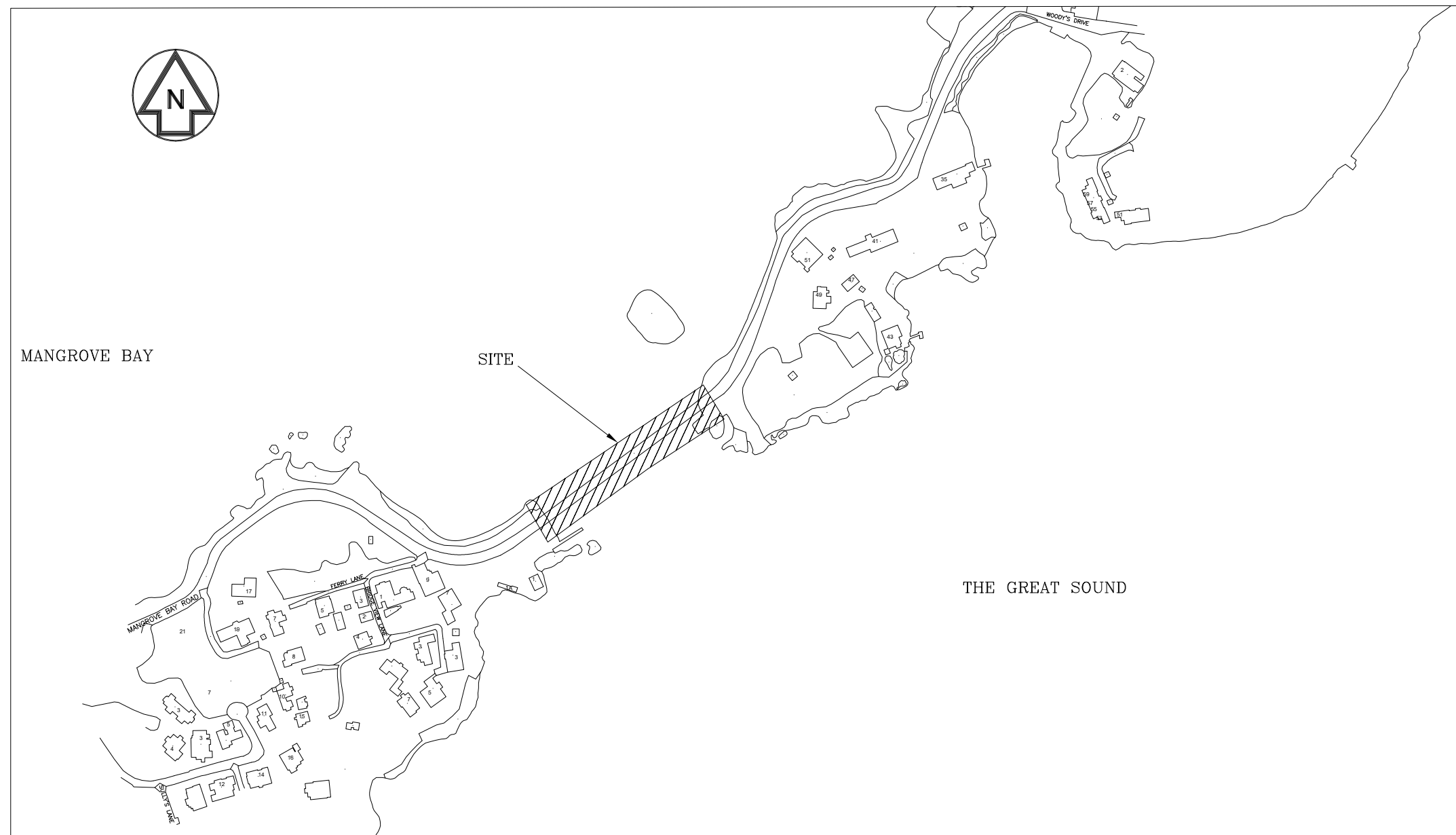

KEY PLAN

ISSUED FOR: TENDER 09/2016

AMENDMENTS:

NO	REVISION	BY	APP	DATE

ISSUED FOR TENDER MAM YL 2017-07-10

SCALE: 1:2000

SURVEY
 PREPARED BY: DATE:

DESIGN
 PREPARED BY: R. CROSSLEY DATE: 01/2011
 CHECKED BY: M. MURPHY DATE: 01/2011

DRAWING
 PREPARED BY: R.GRAHAM-WARD DATE: 08/2016
 CHECKED BY: M.MURPHY DATE: 08/2016

APPROVED BY: J.SAMARASEKERA DATE: 08/2016

PROJECT NUMBER:
 44/11/50

PROJECT NAME:
WATFORD BRIDGE

**WATERPROOFING & EXPANSION
 JOINT REPLACEMENT
 SANDYS PARISH**

SHEET TITLE:
COVER

SHEET NUMBER:
S-0

REVISION
 1

NOTE

1. ORIGINAL PAPER SIZE OF DRAWING IS 34"x22". ALL SCALES SHOWN ARE TO BE HALVED WHEN DRAWING IS PRINTED ON 17"x11" PAPER.

ISSUED FOR: TENDER 09/2016

AMENDMENTS:

NO	REVISION	BY	APPL	DATE

ISSUED FOR TENDER MAM/YL 2017-07-10

SCALE: AS SHOWN

SURVEY
PREPARED BY: DATE:

DESIGN
PREPARED BY: R. CROSSLEY DATE: 01/2011
CHECKED BY: M. MURPHY DATE: 01/2011

DRAWING
PREPARED BY: R. GRAHAM-WARD DATE: 08/2016
CHECKED BY: M. MURPHY DATE: 08/2016

APPROVED BY: Y. LORTIE DATE: 08/2016

PROJECT NUMBER:
44/11/50

PROJECT NAME:
**WATFORD BRIDGE
MAINTENANCE 2016**

**BRIDGE DECK
REPLACEMENT
SANDYS PARISH**

SHEET TITLE:
AREA OF WORKS

SHEET NUMBER:
S-1

REVISION
1

NOTES

1. THE SITE SHALL BE MAINTAINED IN A SAFE MANNER WITH ADEQUATE LIGHTING AND ADVANCED WARNING SIGNS. ONE VEHICULAR AND PEDESTRIAN LANE SHALL BE OPENED AT ALL TIMES.
2. THE CONTRACTOR SHALL REMOVE THE EXISTING BRIDGE DECK SURFACING AND WATERPROOFING MEMBRANE.
3. THE CONTRACTOR SHALL ALSO REMOVE A PORTION OF THE CONCRETE SIDEWALK AS PER THE GRAY SHADED AREA IN THE DRAWING. THE STEEL REINFORCEMENT IN THE AREA SHALL REMAIN IN PLACE.
4. THE CONTRACTOR SHALL REMOVE THE EXISTING BRIDGE DECK JOINTS; ANY METAL FIXINGS FOR THE MECHANISM REMAINING SHALL BE CUT BACK TO GIVE 50mm COVER TO THE REINSTATED CONCRETE BRIDGE DECK SURFACE.
5. THE BRIDGE DECK SHALL BE ADEQUATELY PREPARED IN STRICT ACCORDANCE WITH THE MANUFACTURE'S INSTRUCTION TO RECEIVE THE LIQUID APPLIED WATERPROOFING MEMBRANE FOR THE FULL LENGTH AND WIDTH OF THE BRIDGE DECK AND UP EACH KERB.
6. THE CONTRACTOR SHALL REPAIR THE CONCRETE BRIDGE DECK USING PROPRIETARY HIGH STRENGTH CONCRETE REPAIR MORTAR THAT HAS BEEN APPROVED BY THE ENGINEER AND ACCEPTABLE TO THE JOINT AND WATERPROOFING MANUFACTURERS.
7. THE EXPOSED BRIDGE DECK AND ABUTMENT SURFACES SHALL BE TREATED WITH A TWO PART LIQUID APPLIED WATERPROOFING MEMBRANE.
8. THE DECK SHALL BE RESURFACED BY THE MINISTRY OF PUBLIC WORKS. THE CONTRACTOR SHALL LIAISE WITH THE MINISTRY OF PUBLIC WORKS TO COORDINATE THIS ELEMENT OF THE WORKS.
9. THE SURFACING SHALL BE REINSTATED TO THE CORRECT DEPTH FOR THE DESIGN OF THE JOINT.
10. THE CONTRACTOR SHALL INSURE THAT THE NEW ASPHALT IS CLEANLY CUT AND REMOVED IN THE AREA OF THE DECK JOINT SO THAT A SOUND ASPHALT EDGE IS PRESENTED FOR THE INSTALLATION OF THE JOINT.
11. THE CONTRACTOR SHALL SUPPLY AND INSTALL NEW EXPANSION JOINTS.
12. THE CONTRACTOR SHALL REINSTATE THE CONCRETE IN THE SIDEWALK AREA AFTER APPLYING A BONDING AGENT SUCH AS WELDCRETE TO THE EXISTING STEEL REINFORCEMENT AND TO THE CONTACT FACES BETWEEN NEW AND OLD CONCRETE. THE BONDING AGENT SHALL BE APPLIED IN AGREEMENT WITH MANUFACTURER'S SPECIFICATIONS.
13. THE CONTRACTOR SHALL SUPPLY AND INSTALL STAINLESS STEEL COVER PLATES WHERE THE EXPANSION JOINT PASSES THROUGH THE SIDEWALKS AND KERBS.
14. THE CONTRACTOR SHALL SUPPLY AND INSTALL TWO PART POLYSULPHIDE JOINT FILLER.

BRIDGE DECK/SIDEWALK SHOWN
IN HATCHED AREA TO BE
REPLACED TYP BOTH SIDES

WEST SIDE

HAND RAIL

STAINLESS STEEL CHECKER
PLATES INSTALLED OVER NEW
BRIDGE DECK JOINTS IN
SIDEWALK, TYP BOTH SIDES.
PLEASE REFER TO SECTION
F-F AND SECTION G-G OF
"DECK SLAB GENERAL
ARRANGEMENT" OF THE NEW
WATFORD BRIDGE DRAWING.

SCALE: 1:100



EAST SIDE

centerline road marking

WATERS OF MANGROVE BAY
MANGROVE BAY ROAD

SUPPLY AND INSTALL
WATERPROOFING MEMBRANE
OVER THE FULL LENGTH AND
WIDTH OF THE BRIDGE DECK
AND UP THE KERBS

WATERS OF THE GREAT SOUND

EAST SIDE

EXPANSION JOINT

KERB

HAND RAIL

SIDEWALK

STAINLESS STEEL CHECKER
PLATES INSTALLED OVER NEW
BRIDGE DECK JOINTS IN
SIDEWALK, TYP BOTH SIDES

BRIDGE DECK/SIDEWALK SHOWN
IN HATCHED AREA TO BE
REPLACED TYP BOTH SIDES

LEGEND

- + Denotes spot levels
- - - Overhead Wires
- LP light pole
- G Grate
- IC Inspection Covers

SCALE: 1:250

SCALE: 1:100

Structures Section

NOTES:

1. THE JOINT SHALL BE DESIGNED TO ACCOMMODATE A MOVEMENT OF +/- 19mm ON THE WEST END AND +/- 28mm ON THE EAST END. THE JOINT SHALL NOT REQUIRE MECHANICAL FIXINGS INTO THE CONCRETE BRIDGE DECK.
 2. ASPHALTIC PLUG JOINT AS SUPPLIED BY UNIVERSAL SEALANTS LIMITED IS CONSIDERED ACCEPTABLE FOR THIS JOINT. ALTERNATIVELY A BRITFLEX NJ EXPANSION JOINT AS SUPPLIED BY UNIVERSAL SEALANTS LIMITED IS CONSIDERED ACCEPTABLE.
- THE MINISTRY OF PUBLIC WORKS WILL CONSIDER ANY ALTERNATIVE PROPOSALS THAT DO NOT REQUIRE MECHANICAL FIXING TO THE CONCRETE DECK.
3. ORIGINAL PAPER SIZE OF DRAWING IS 34"x22". ALL SCALES SHOWN ARE TO BE HALVED WHEN DRAWING IS PRINTED ON 17"x11" PAPER.

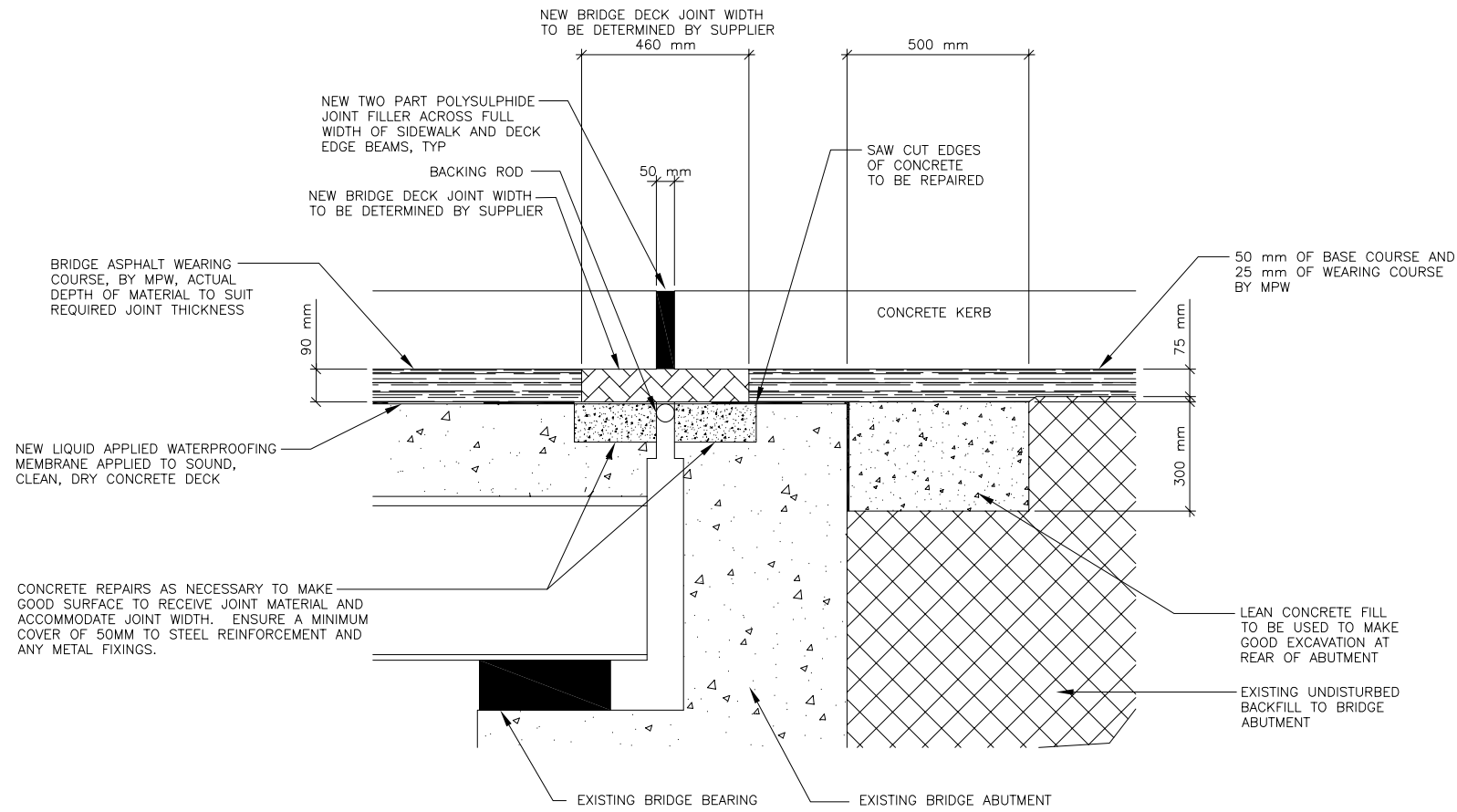

SECTION AT ABUTMENT

SCALE: 1:10

ISSUED FOR: TENDER

AMENDMENTS:

NO	REVISION	BY	APP	DATE

SCALE: AS SHOWN

SURVEY

PREPARED BY: DATE:

DESIGN

PREPARED BY: R. CROSSLEY DATE: 01/2011
CHECKED BY: M. MURPHY DATE: 01/2011

DRAWING

PREPARED BY: R. GRAHAM-WARD DATE: 08/2016
CHECKED BY: M. MURPHY DATE: 03/2017

APPROVED BY: Y. LORTIE DATE: 03/2017

PROJECT NUMBER:
44/11/50

PROJECT NAME:
WATFORD BRIDGE

**WATERPROOFING & EXPANSION
JOINT REPLACEMENT
SANDYS PARISH**

SHEET TITLE:

BRIDGE JOINT DETAILS

SHEET NUMBER:

S-2

REVISION

1

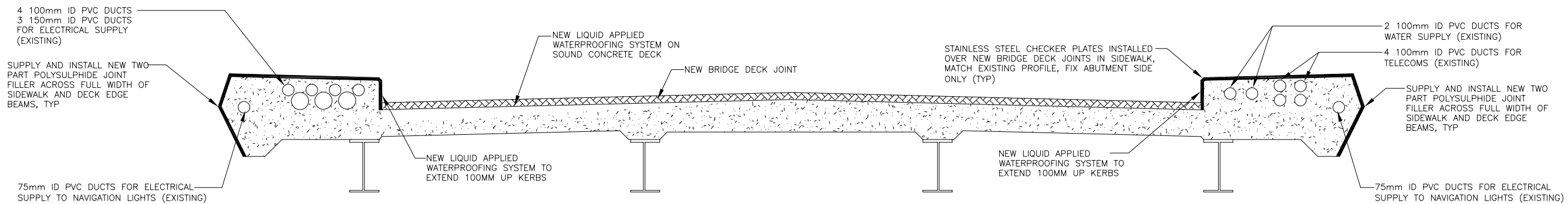

DECK CROSS SECTION

SCALE: 1:20

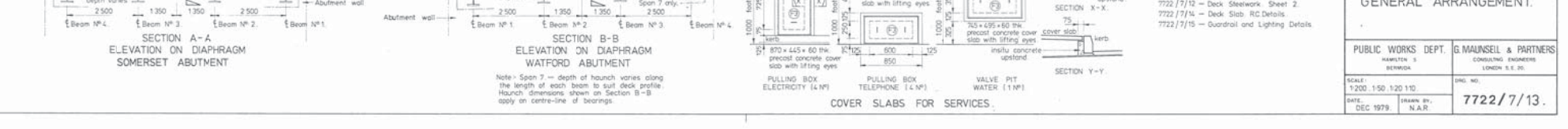
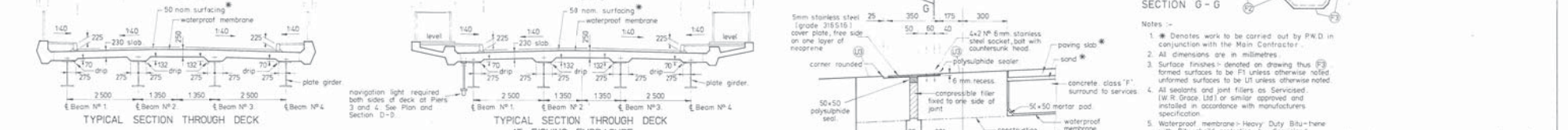
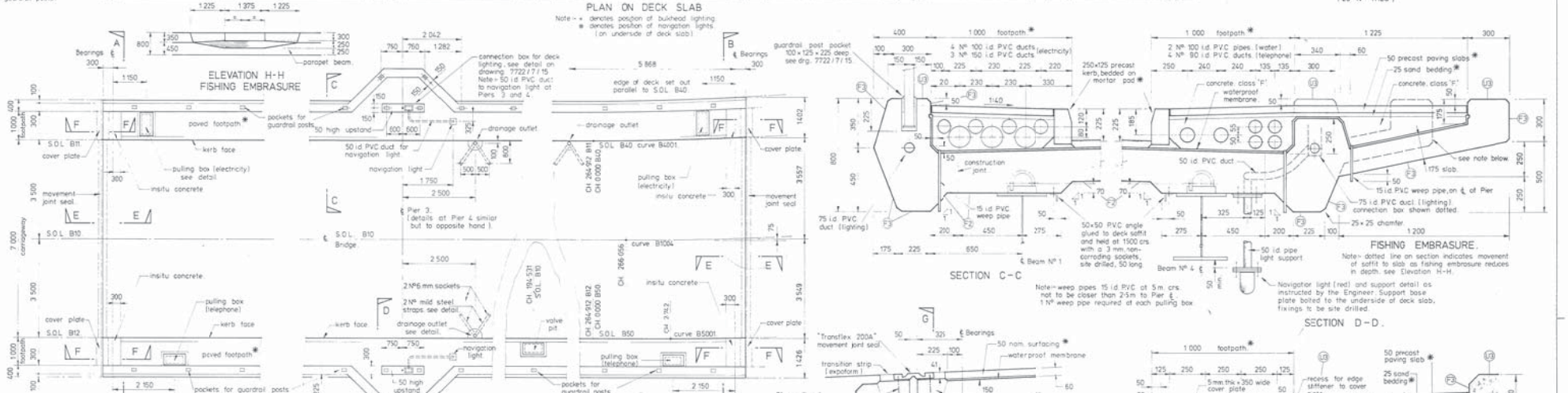
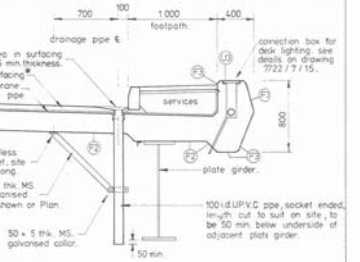
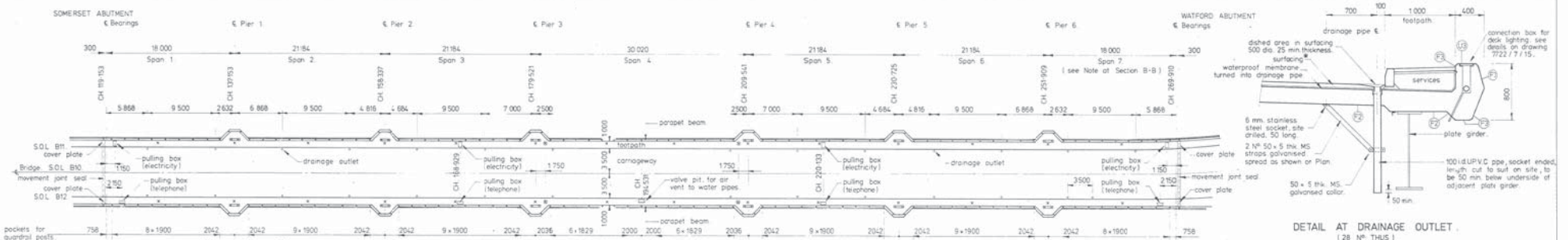

- Notes -
1. Denotes work to be carried out by P.W.D. in conjunction with the Main Contractor.
 2. All dimensions are in millimetres.
 3. Surface finishes - denoted on drawing thus (F3) formed surfaces to be F3 unless otherwise noted. Unformed surfaces to be U1 unless otherwise noted.
 4. All sealants and joint fillers are Serviced.
 5. Waterproof membrane - Heavy Duty Bitu-hene with Bitu-shield protection, by Serviced (W R Grace Ltd) or similar approved and installed in accordance with manufacturer's specification.
 6. Movement joint - Transflex 200A by Expoxide Ltd or similar approved and installed in accordance with manufacturer's specification.
 7. This drawing to be read in conjunction with the following drawings:-
 7722/7/2 - Vertical and Horizontal Alignments (and the Setting Out Book)
 7722/7/6 - Somerset Abutment G.A.
 7722/7/8 - Watford Abutment G.A.
 7722/7/11 - Deck Steelwork Sheet 1.
 7722/7/12 - Deck Steelwork Sheet 2.
 7722/7/14 - Deck Slab RC Details.
 7722/7/15 - Guttering and Lighting Details.

REV.	DESCRIPTION	DATE	CHECKED
GOVERNMENT OF BERMUDA			
NEW WATFORD BRIDGE			
DECK SLAB			
GENERAL ARRANGEMENT.			

PUBLIC WORKS DEPT. HAMILTON BERMUDA	G. MAUNSELL & PARTNERS CONSULTING ENGINEERS LONDON E.C. 20.
SCALE: 1:200, 1:50, 1:20, 1:10.	DWG. NO.: 7722/7/13.
DATE: DEC 1979.	DRAWN BY: N.A.R.

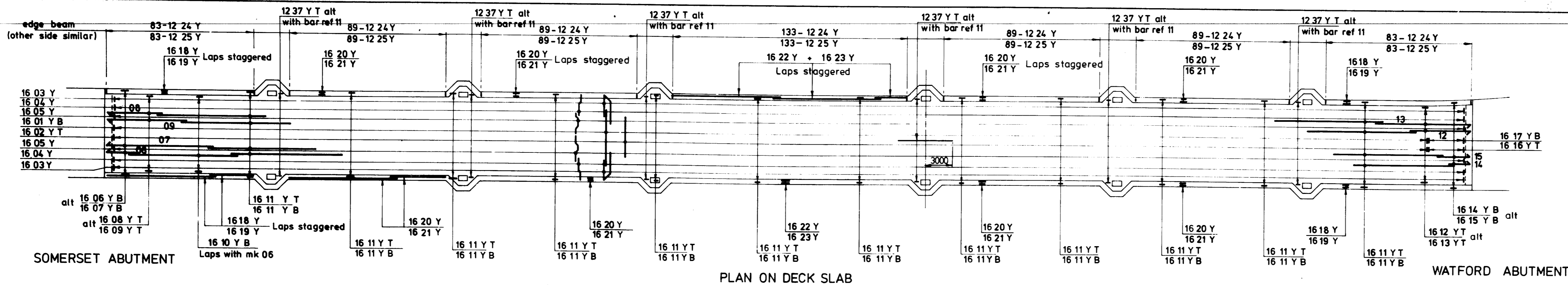

PLAN ON DECK SLAB

BAR LOCATING TABLE					
Bending Schedule No 23181					
Bar mark	Grouping	Shape	Crs.	Total	
DECK SLAB (1 NO)					
16 01 Y	1 x 1221	20	120	1221	
16 02 Y	1 x 977	20	120	977	
16 03 Y	2 x 1255	39	120	2510	
16 04 Y	2 x 1255	42	120	2510	
16 05 Y	2 x 1295	43	120	2510	
16 06 Y	1 x 21	37	450	21	
16 07 Y	1 x 21	37	450	21	
16 08 Y	1 x 21	37	450	21	
16 09 Y	1 x 21	37	450	21	
16 10 Y	1 x 21	37	450	21	
16 11 Y	2 x 21	37	450	21	
16 12 Y	1 x 21	37	450	21	
16 13 Y	1 x 21	37	450	21	
16 14 Y	1 x 21	37	450	21	
16 15 Y	1 x 21	37	450	21	
16 16 Y	1 x 21	37	450	21	
16 17 Y	1 x 21	37	450	21	
16 18 Y	1 x 21	37	450	21	
16 19 Y	1 x 21	37	450	21	
16 20 Y	1 x 21	37	450	21	
16 21 Y	1 x 21	37	450	21	
16 22 Y	1 x 21	37	450	21	
16 23 Y	1 x 21	37	450	21	
16 24 Y	1 x 655	9962	200	655	
16 25 Y	1 x 655	9963	200	655	
16 26 Y	6 x 81	20	225	246	
EDGE BEAM (2 NO)					
16 18 Y	2 x 8	20	16	16	
16 19 Y	2 x 8	20	16	16	
16 20 Y	4 x 8	20	32	32	
16 21 Y	4 x 8	20	32	32	
16 22 Y	1 x 8	20	8	8	
16 23 Y	2 x 8	20	16	16	
16 24 Y	1 x 655	9962	200	655	
16 25 Y	1 x 655	9963	200	655	
16 26 Y	7 x 3	2	20	146	
SOMERSET DIAPHRAGM (1 NO)					
25 26 Y	1 x 5	20	5	5	
25 27 Y	1 x 2	20	2	2	
25 28 Y	2 x 5	38	10	10	
25 29 Y	1 x 4	35	8	8	
16 30 Y	2 x 2	74	4	4	
16 31 Y	2 x 2	74	4	4	
16 32 Y	2 x 2	74	4	4	
16 33 Y	2 x 2	74	4	4	
16 34 Y	2 x 2	74	4	4	
16 35 Y	2 x 2	74	4	4	
16 36 Y	2 x 2	74	4	4	
16 37 Y	2 x 2	74	4	4	
16 38 Y	2 x 2	74	4	4	
16 39 Y	2 x 2	74	4	4	
16 40 Y	2 x 2	74	4	4	
16 41 Y	2 x 2	74	4	4	
16 42 Y	2 x 2	74	4	4	
16 43 Y	2 x 2	74	4	4	
16 44 Y	2 x 2	74	4	4	
16 45 Y	2 x 2	74	4	4	
16 46 Y	2 x 2	74	4	4	
16 47 Y	2 x 2	74	4	4	
16 48 Y	2 x 2	74	4	4	
16 49 Y	2 x 2	74	4	4	
16 50 Y	2 x 2	74	4	4	
16 51 Y	2 x 2	74	4	4	
16 52 Y	1 x 7	74	8	8	
16 53 Y	1 x 8	74	8	8	
WATFORD DIAPHRAGM (1 NO)					
25 40 Y	1 x 5	20	5	5	
25 41 Y	1 x 4	35	8	8	
25 42 Y	1 x 4	35	8	8	
25 43 Y	2 x 2	74	4	4	
25 44 Y	1 x 2	20	2	2	
16 45 Y	1 x 4	74	4	4	
16 46 Y	1 x 4	74	4	4	
16 47 Y	1 x 4	74	4	4	
16 48 Y	1 x 4	74	4	4	
16 49 Y	1 x 4	74	4	4	
16 50 Y	1 x 4	74	4	4	
16 51 Y	1 x 4	74	4	4	
16 52 Y	1 x 7	74	8	8	
16 53 Y	1 x 8	74	8	8	
FISHING EMBRASURE (2 NO)					
16 61 Y	2 x 1	62	2	2	
16 62 Y	2 x 2	62	4	4	
16 63 Y	2 x 2	62	4	4	
16 64 Y	2 x 1	62	2	2	
16 65 Y	1 x 2	62	2	2	
16 66 Y	1 x 1	45	1	1	
16 67 Y	1 x 1	55	1	1	
16 68 Y	2 x 1	62	2	2	
12 69 Y	2 x 1	62	2	2	
12 70 Y	1 x 1	62	1	1	
12 71 Y	1 x 1	62	1	1	
12 72 Y	1 x 10	62	10	10	
12 73 Y	1 x 5	62	5	5	
12 74 Y	2 x 5	62	10	10	
12 75 Y	2 x 5	62	10	10	
10 76 Y	2 x 8	39	150	16	
16 77 Y	2 x 6	62	150	12	
16 78 Y	2 x 4	62	240	8	
12 79 Y	2 x 5	9962	200	10	
16 80 Y	1 x 6	62	150	4	
12 81 Y	1 x 8	9962	200	8	
16 82 Y	1 x 2	20	2	2	
12 83 Y	1 x 18	9963	200	18	
JOINT NOSING (1 NO)					
12 90 Y	3 x 3	20	9	9	
6 91 Y	1 x 47	9931	150	47	
FOOTPATH BLOCK (4 NO)					
12 95 Y	1 x 4	37	150	4	
12 96 Y	1 x 4	37	150	4	
12 97 Y	1 x 4	37	150	4	
12 98 Y	1 x 7	20	150	7	
PRECAST COVERS FOR SERVICES MESH TO B.S.-B283					

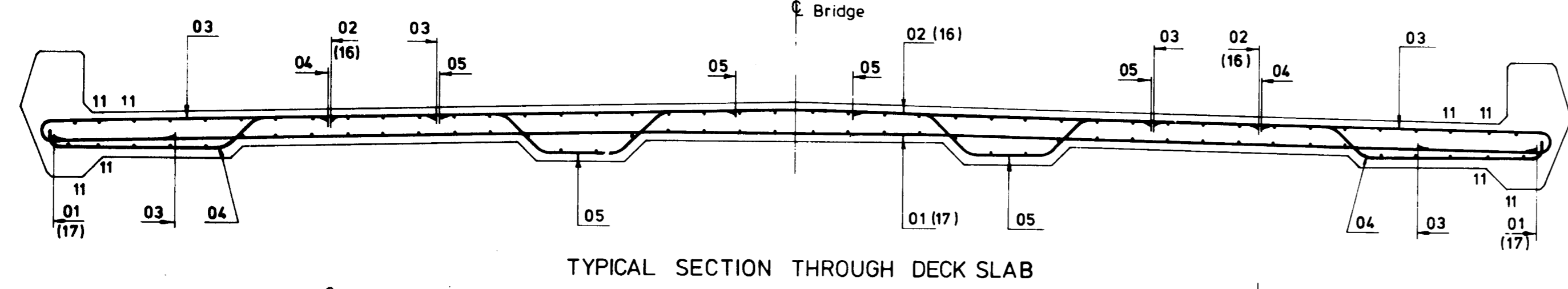

TYPICAL SECTION THROUGH DECK SLAB

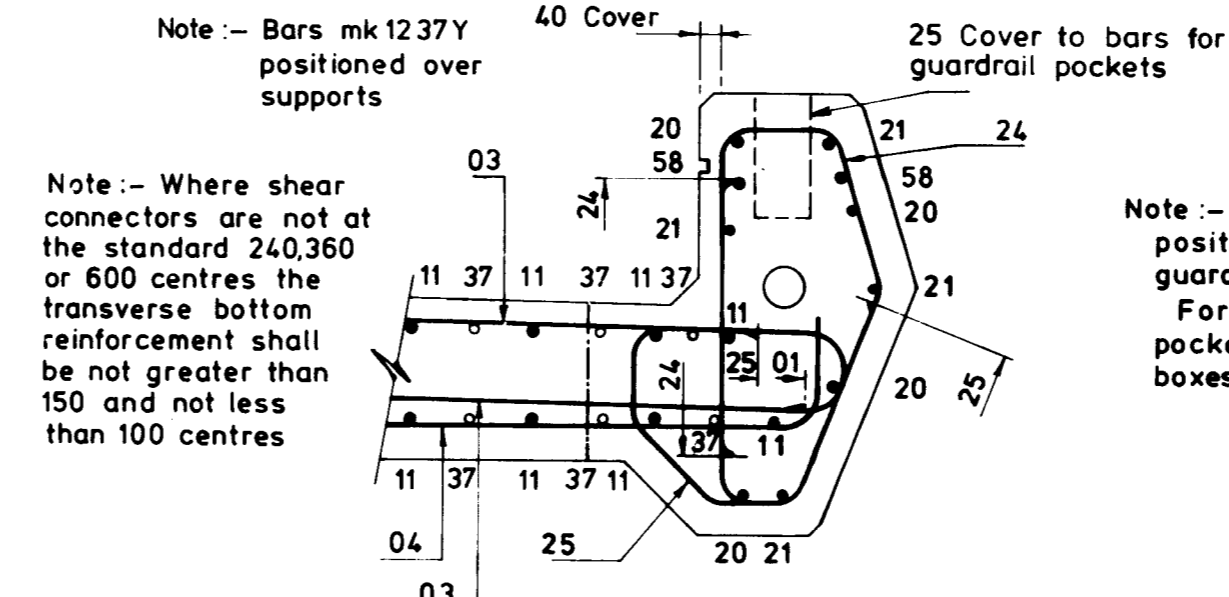

EDGE BEAM DETAIL

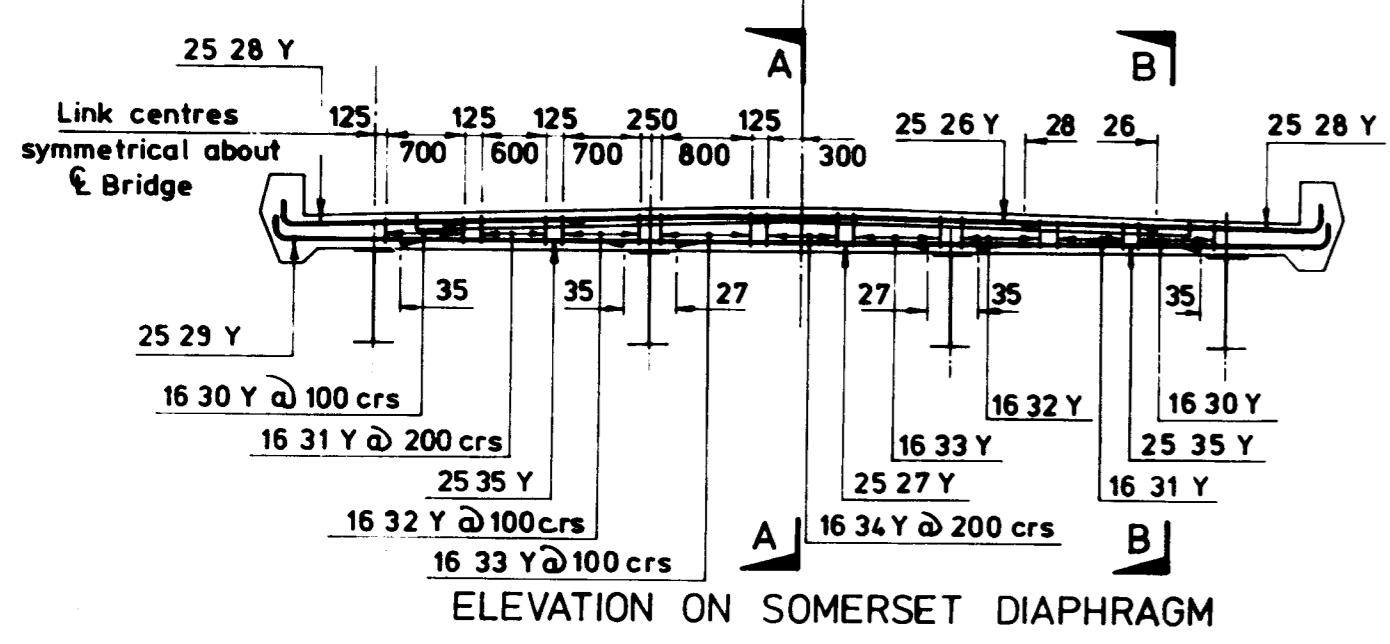

ELEVATION ON SOMERSET DIAPHRAGM

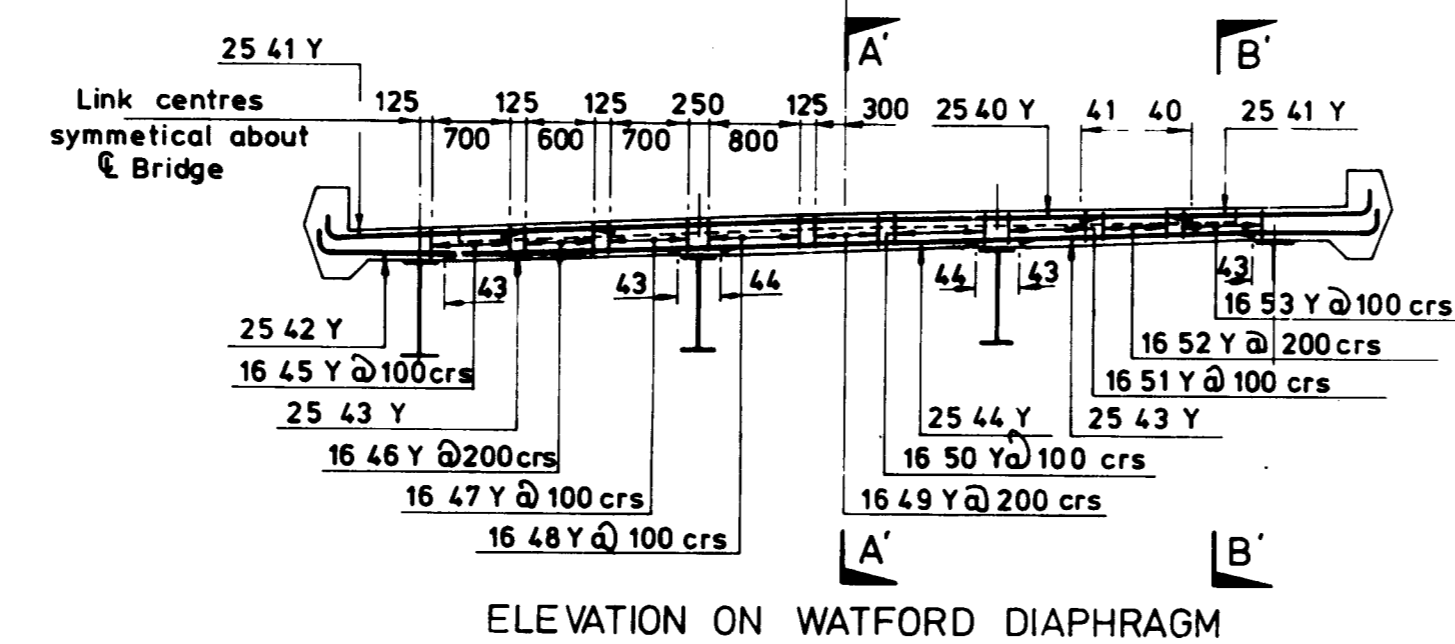

ELEVATION ON WATFORD DIAPHRAGM

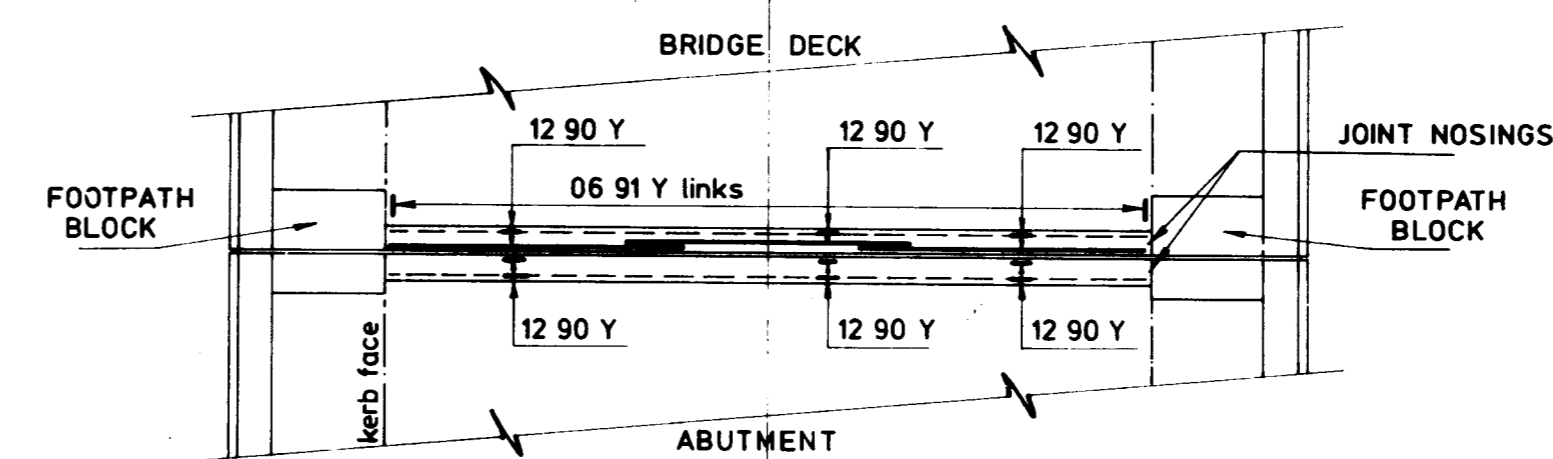

PLAN ON END OF DECK

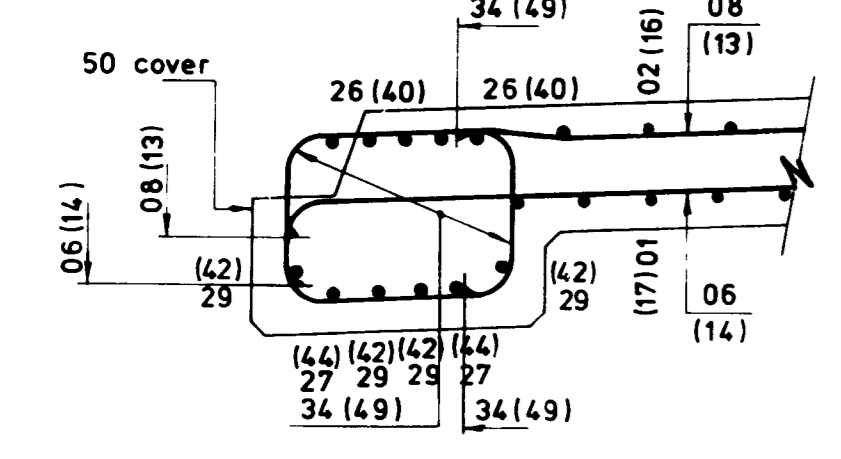

SECTION A-A

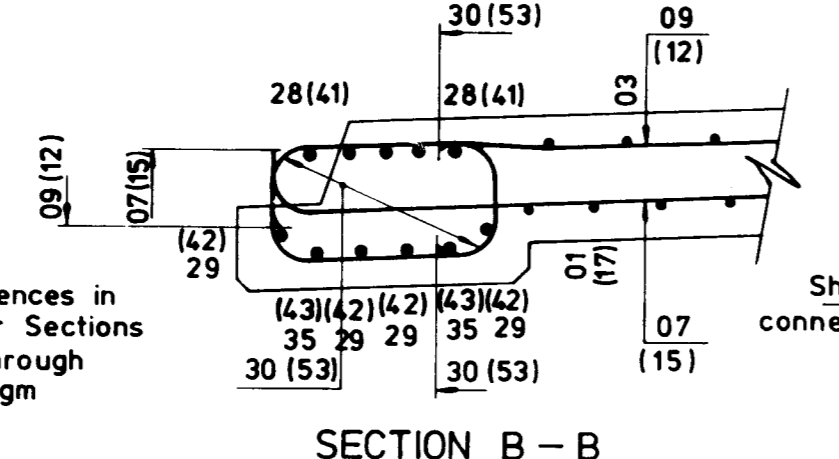

SECTION B-B

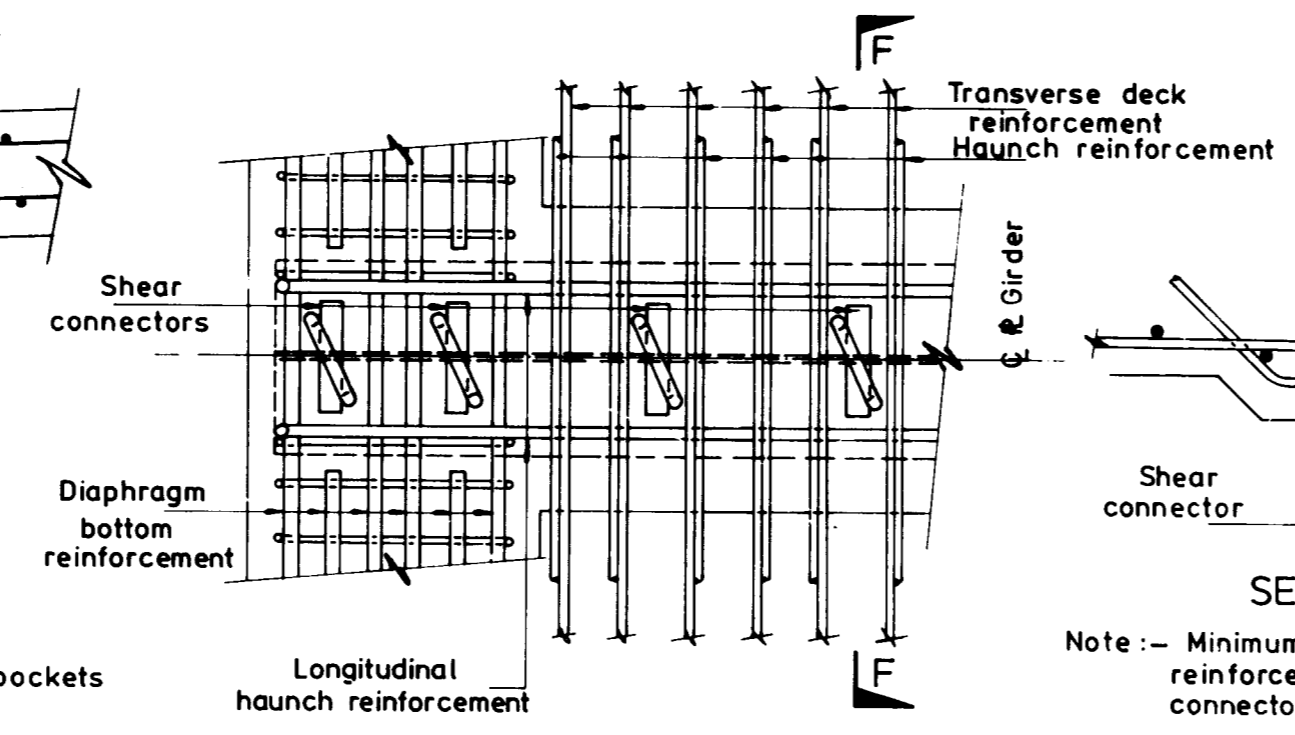

TYPICAL DETAILS OF BAR POSITIONING AROUND SHEAR CONNECTORS

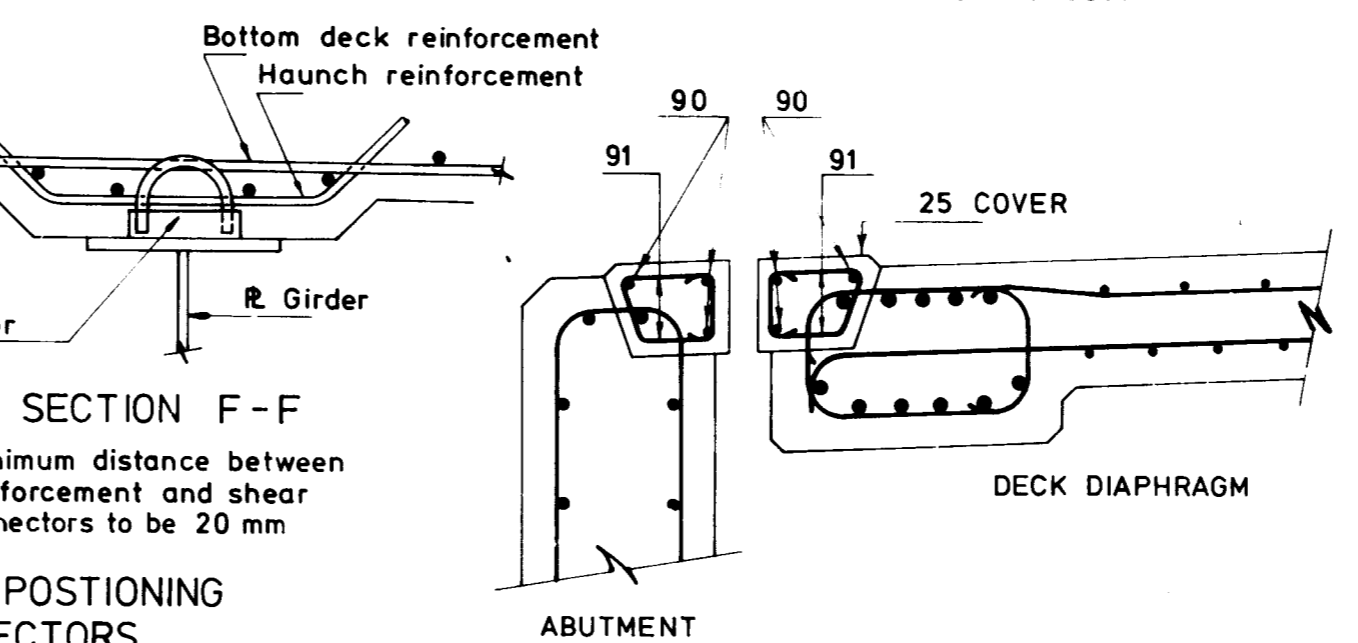

DETAIL OF JOINT NOSINGS (2 No Thus)

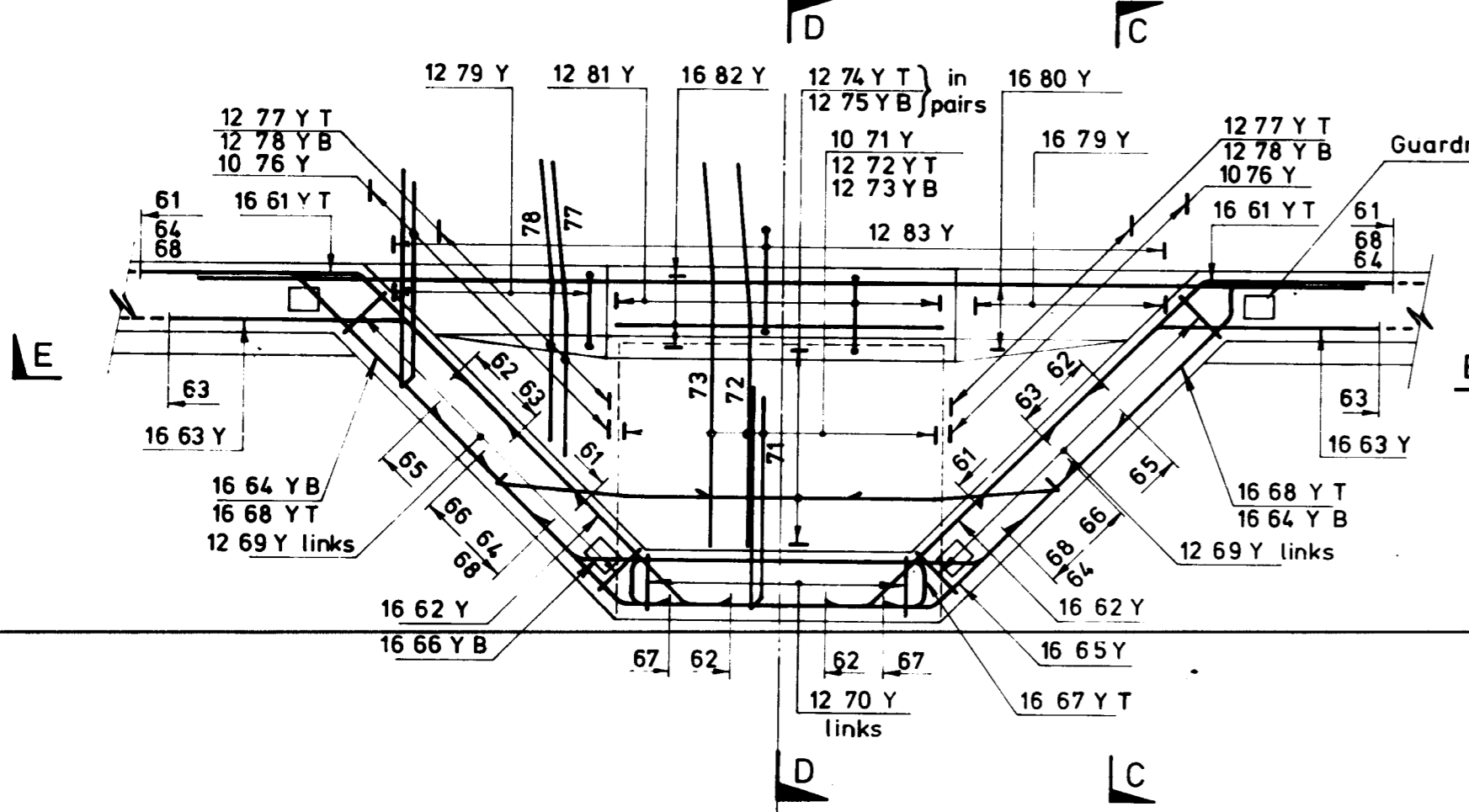

PLAN ON FISHING EMBRASURE

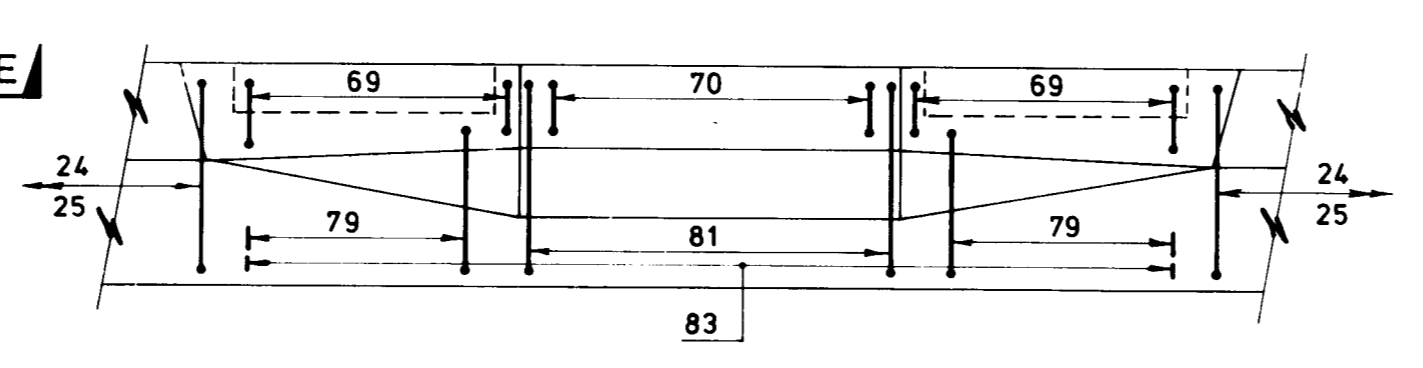

ELEVATION ON FISHING EMBRASURE

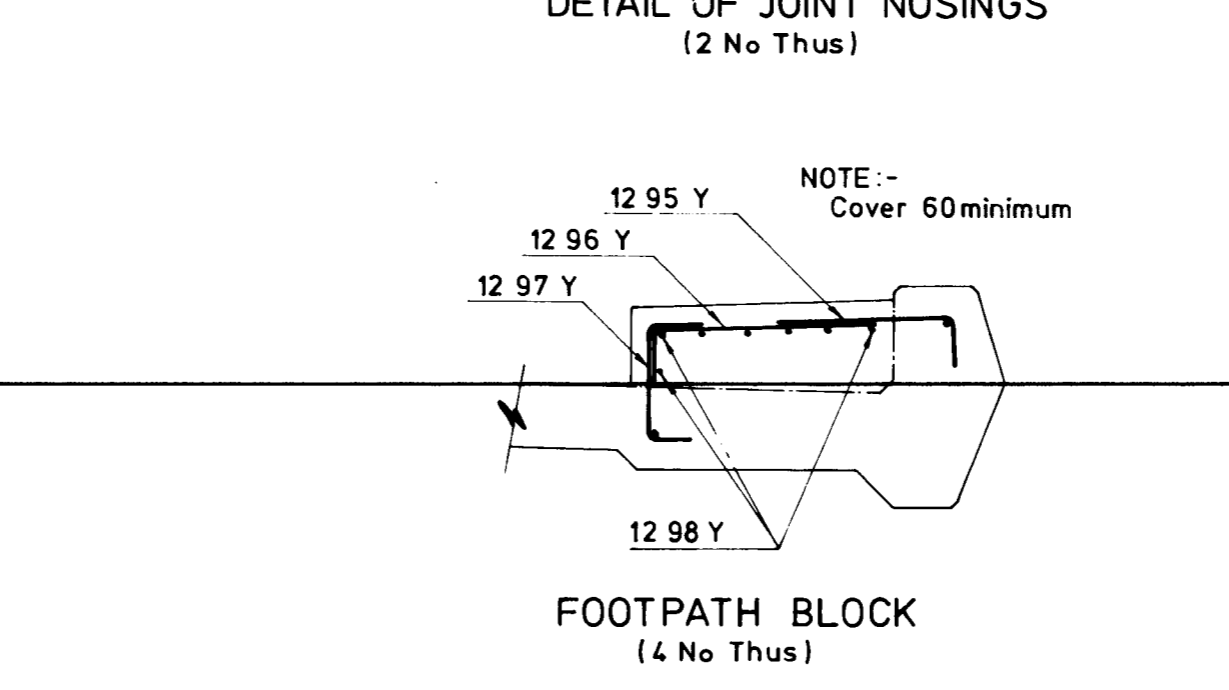

FOOTPATH BLOCK (4 No Thus)

- Notes :-
- All dimensions are in millimetres
 - Concrete class - Class 30/20 - Deck slab, PC Covers & Footpath block
 - Cover to reinforcement - Unless otherwise stated Edge beam 60 minimum Soffit haunches 60 minimum Soffit of deck slab 50 minimum Top of deck slab 40 minimum
 - Reinforcement - a) all bars to be high yield deformed bars to B.S.4449 and galvanised in accordance with B.S.729 see Specification clause 1506 High yield bars are shown as bar type Y b) bar mark 20 10 Y bar type reference number bar diameter c) lap lengths to be 42 x bar diameter minimum d) abbreviations used in bar call-up T = top, B = bottom, alt = alternate

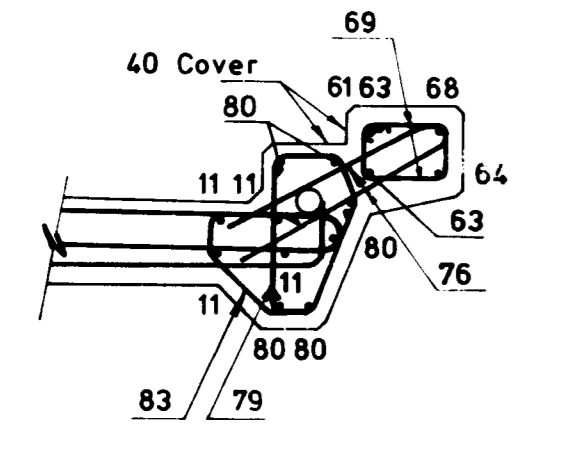

SECTION C-C

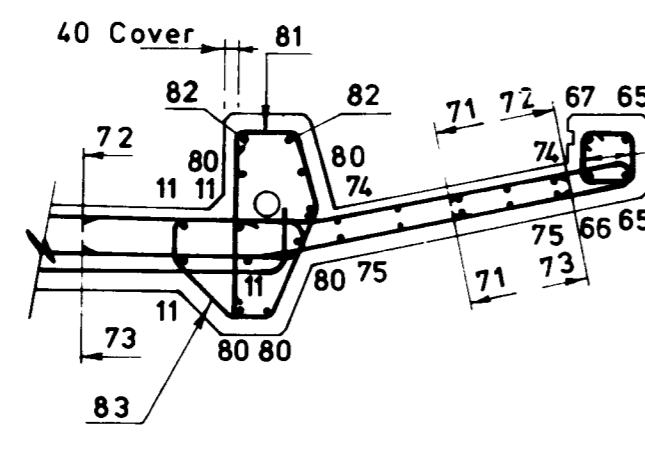

SECTION D-D

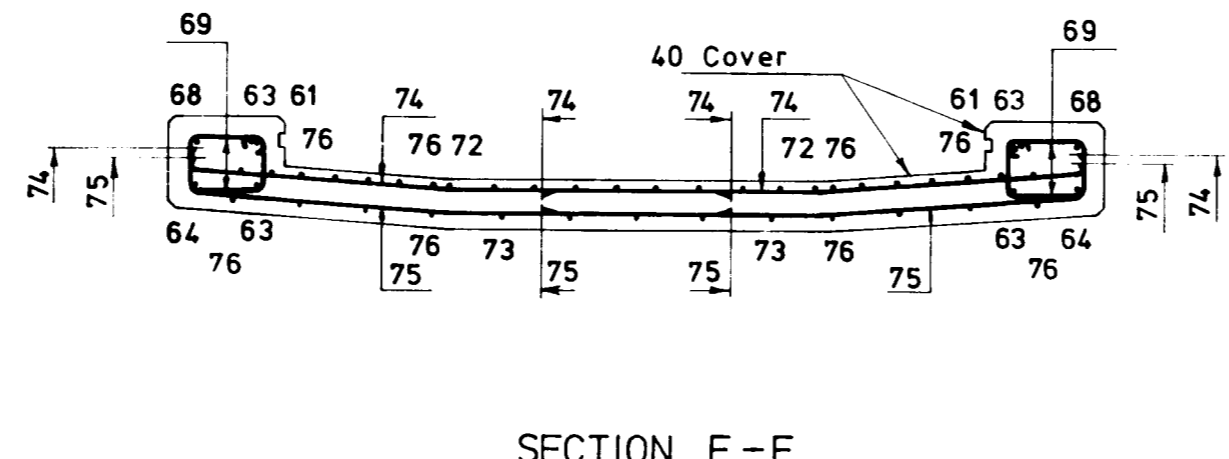

SECTION E-E

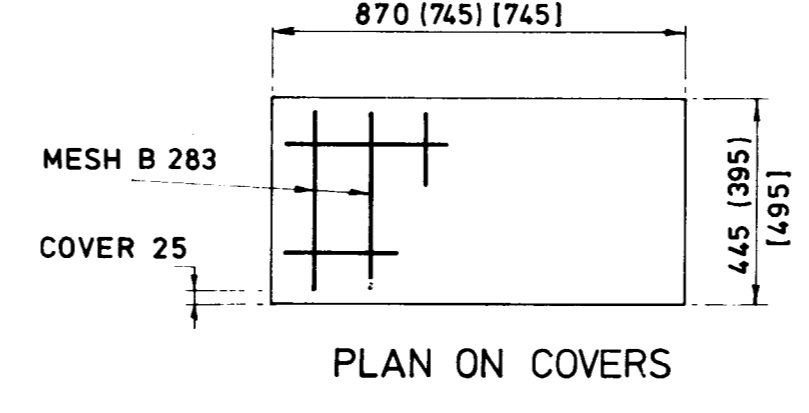

PLAN ON COVERS

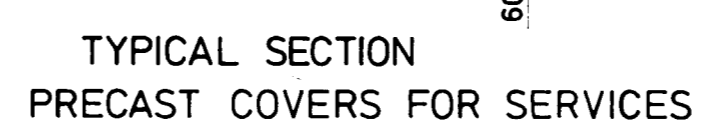

TYPICAL SECTION PRECAST COVERS FOR SERVICES

COVER SCHEDULE :-
 4 NO ELECTRICITY PULLING BOX COVERS 870 x 445
 4 NO TELEPHONE PULLING BOX COVERS 745 x 395
 1 NO WATER AIR VENT COVER 745 x 495

REV.	DESCRIPTION	DATE	CHECKED
GOVERNMENT OF BERMUDA			
NEW WATFORD BRIDGE			
DECK SLAB R.C. DETAILS			
PUBLIC WORKS DEPT. HAMILTON 5 BERMUDA		G. MAUNSELL & PARTNERS CONSULTING ENGINEERS LONDON S.E. 20.	
SCALE 1:10, 1:20, 1:50, 1:200	DATE MAY 1979		
DRAWN BY G.J.H.		DRG. NO. 7722/3/18	



Figure 1 : Watford Bridge Looking North



Figure 2: Watford Bridge Looking South

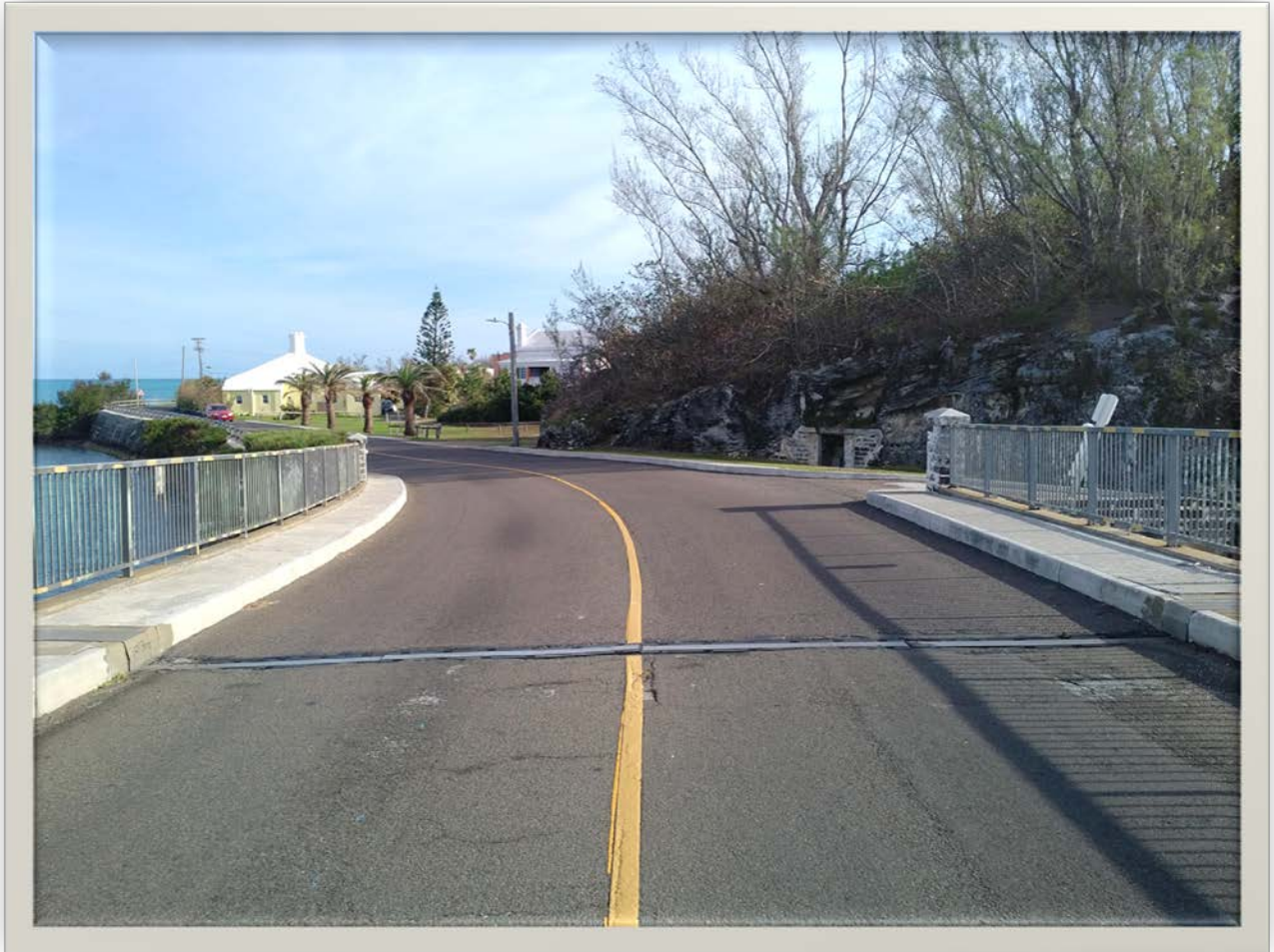

Figure 3: Watford Bridge Approaches Looking North



Figure 4: North Expansion Joint



Figure 5: South Expansion Joint