

# MINISTRY OF WORKS AND ENGINEERING



## REPLACEMENT FERRY PROJECT PHASE 1 DOCK CONSTRUCTION PROJECT NO. 61/01/01 MAY 2001

REFERENCE ONLY

DRAWING LIST		
DRAWING #	TITLE	CURRENT REVISION
<b>GENERAL DRAWINGS</b>		
T1	TITLE SHEET	B
T2	GENERAL NOTES	B
T3	STANDARD BARGE UNITS	B
T4	STANDARD BARGE ATTACHMENTS	B
T5	STANDARD ALUMINUM PLATFORMS	--
T6	STANDARD ALUMINUM GANGWAYS & RAMPS	--
<b>HAMILTON DEPOT</b>		
HD1	EXISTING CONDITIONS	--
HD2	SITE LAYOUT	B
HD3	BARGE ASSEMBLY PLAN	B
HD4	ALUMINUM ASSEMBLY PLAN	B
HD5	ASSEMBLY CONNECTIONS	B
HD6	BALLASTING PLAN	B
HD7	PIER PILE & PILE CAP PLAN	A
HD8	PIER PILE CAP DETAILS	--
HD9	STRUCTURE ALTERNATIVES	--
HD10	MISCELLANEOUS CONCRETE DETAILS	B
HD11	WALL AND VESSEL FENDER	A
HD12	MOORING PILES	B
HD13	MISC. DETAILS	B

DRAWING LIST		
DRAWING #	TITLE	CURRENT REVISION
<b>HAMILTON TERMINAL</b>		
A1	PROPOSED LAYOUT PLAN AND ELEVATION	B
A2	LANDSIDE WORKS - ALTERATIONS TO EXISTING	A
A3	LANDSIDE WORKS - PLAN AND ELEVATION	A
A4	LANDSIDE WORKS - SECTIONS AND DETAILS	A
HT1	EXISTING CONDITIONS	--
HT2	SITE PLAN	B
HT3	BARGE ASSEMBLY PLAN	B
HT4	ALUMINUM ASSEMBLY PLAN	B
HT5	ASSEMBLY CONNECTION DETAILS	B
HT6	BALLASTING PLAN	B
HT7	CANOPY	--
HT8	WALL NOTCH CONSTRUCTION	--
HT9	WALL DETAILS	--
HT10	GANGWAY PIER EXTENSION	--
HT11	WALL FENDER	--
HT12	MOORING PILES	B
HT13	MISC. DETAILS	B
<b>DOCKYARD</b>		
DY1	EXISTING CONDITIONS	--
DY2	**SHEET DELETED**	B
DY3	BARGE & ALUMINUM ASSEMBLY PLAN	B
DY4	ASSEMBLY CONNECTIONS	B
DY5	BALLASTING PLAN	B
DY6	GANGWAY NOTCH PLAN & DETAILS	--
DY7	WALL FENDER	--
DY8	**SHEET DELETED**	B
DY9	FENDER DETAILS	B
DY10	MISC. DETAILS	B
DY11	MOORING LAYOUT	B
DY12	MOORING DETAILS	B

DRAWING LIST		
DRAWING #	TITLE	CURRENT REVISION
<b>ST. GEORGE'S</b>		
SG1	EXISTING CONDITIONS	--
SG2	SITE LAYOUT	B
SG3	BARGE & ALUMINUM ASSEMBLY PLAN	B
SG4	ASSEMBLY CONNECTION	B
SG5	BALLASTING PLAN	B
SG6	PIER PLAN AND DETAILS	--
SG7	MOORING PILES	B
SG8	MISC. DETAILS	B
SG9	PLAN, SECTIONS AND DETAILS	--
<b>ROCKAWAY TERMINAL</b>		
RW1	EXISTING CONDITIONS	--
RW2	SITE LAYOUT	--
RW3	ACCESS RAMP PLAN & ELEVATION	B
RW4	ACCESS RAMP REINFORCING DETAILS	A
RW5	OUTSHORE PLATFORM AND SUSPENDED SLAB	--
RW6	PIER PLAN & ELEVATIONS	--
RW7	PIER PILE/PILECAP PLAN & ELEVATIONS	--
RW8	PILE & PILE CAP DETAILS	--
RW9	SHEETING ELEVATION & DETAILS	--
RW10	PIER STRUCTURE ALTERNATIVES	--
RW11	PIER NOTCH PLAN & ELEVATIONS	--
RW12	PIER ATTACHMENT DETAILS	--
RW13	BERTHING DOLPHINS	--
RW14	DOLPHIN DETAILS	--
RW15	GANGWAY HOIST PLAN & DETAILS	--
RW16	DOLPHIN ASSEMBLY PLANS & DETAILS	B
RW17	MISC. DETAILS	--

THE MINISTRY OF  
WORKS AND  
ENGINEERING

P.O. Box HM525 Hamilton HMCX Bermuda  
Phone: (441)295-5151

ENGINEERING and  
OPERATIONS DIVISION  
Fax: (441)295-0170

Structures Section



GENERAL NOTES:

ISSUED FOR: REFERENCE ONLY 2016 09 07

AMENDMENTS:			
NO.	REVISION	APP	DATE
B	NOTES	RRB	04/01/02
C	REFERENCE ONLY	MAM	2016 09 07

SCALE: NO SCALE

SURVEY	
PREPARED BY:	DATE:
RRB	23/05/01
DESIGN	
PREPARED BY:	DATE:
RRB	23/05/01
CHECKED BY:	DATE:
RRB	23/05/01
DRAWING	
PREPARED BY:	DATE:
RRB	23/05/01
CHECKED BY:	DATE:
RRB	23/05/01
APPROVED BY:	RRB

PROJECT NUMBER:  
61/01/01

PROJECT NAME:  
**REPLACEMENT FERRY PROJECT  
PHASE I  
DOCK CONSTRUCTION**

DRAWING FILE NO: ACAD R-14  
TITLE SHT REV.dwg

SHEET TITLE:  
**TITLE SHEET**

SHEET NUMBER: 61/01/01/T1	REVISION A
------------------------------	---------------

**Reference Drawings**

## GENERAL NOTES:

ALL ELEVATIONS ARE IN ORDNANCE DATUM  
MEAN HIGH WATER (MHW) = 0.80 m  
MEAN LOW WATER (MLW) = -0.60 m

### HURRICANE STORM SURGE ELEVATIONS

Terminal Location	Cat 1 Hurricane	Cat 3 Hurricane	Cat 5 Hurricane
	Max Surge (m)	Max Surge (m)	Max Surge (m)
Hamilton Depot	0.79	1.56	2.34
Hamilton Terminal	0.79	1.56	2.34
Rockaway	1.72	3.05	4.39
Dockyard	0.82	1.52	2.33
St. George's	0.56	1.05	1.63

### DESIGN LOADS

Ramps and Platforms (uniform)	4800 N/M <sup>2</sup>
Ramps and Platforms Concentrated	1335 N (25 cm <sup>2</sup> Area)
Guardrails (uniform)	1460 N/M
Guardrails (concentrated)	1110 N
Handrails (uniform)	730 N/M
Handrails (concentrated)	1110 N
Wind Load (110 MPH sustained with gusting factor)	2000 N/M <sup>2</sup>

### Vessel Berthing Speed

	Side	4.6 KPH
		Bow
Normal	Bow	2.8 KPH
	Side	10 KPH
Extreme	Bow	5 KPH

### Vessel Design Freeboard

Catamaran Bow	2300 mm
Catamaran Side	1600 mm
Warwick Class	1070 mm
Somerset Class	1070 mm

### Barge Design Freeboard

Type I, II	1380 mm
Type III, IV	1080 mm

## CODES

AMERICAN SOCIETY FOR TESTING AND MATERIALS (ASTM)  
AMERICAN WELDING SOCIETY (AWS)  
AMERICAN INSTITUTE OF STEEL CONSTRUCTION (AISC)  
ALUMINUM ASSOCIATION SPECIFICATIONS FOR ALUMINUM STRUCTURES  
AMERICAN CONCRETE INSTITUTE (ACI)  
CONCRETE REINFORCING STEEL INSTITUTE (CRSI)  
AMERICAN BUREAU OF SHIPPING - RULES FOR BUILDING AND CLASSING STEEL BARGES (ABS)  
STEEL STRUCTURES PAINTING COUNCIL (SSPC)  
BERMUDA BUILDING CODE  
BOCA NATIONAL BUILDING CODE

## FOUNDATION

### PILE CAPACITY

MOORING PILE TYPE I	15 TONS
MOORING PILE TYPE II	25 TONS
MOORING PILE TYPE III	25 TONS
ALL BEARING PILES	50 TONS
HAMILTON TERMINAL DOLPHIN	60 TONS TOTAL CAPACITY FOR GROUP

### BEARING CAPCITY

ROCKAWAY RETAINING WALLS	TSF
--------------------------	-----

## STRUCTURAL STEEL

AMERICAN INSTITUTE OF STEEL CONSTRUCTION (AISC) SPECIFICATION FOR THE DESIGN, FABRICATION AND ERECTION OF STRUCTURAL STEEL FOR BUILDINGS, LATEST EDITIONS

ALL STEEL PLATE AND ANGLES SHALL BE WEATHERING STEEL AND SHALL CONFORM TO ASTM A588 GRADE A. THE MINIMUM ATMOSPHERIC CORROSION INDEX SHALL BE 8.

ALL OTHER STRUCTURAL STEEL SHAPES, UNLESS OTHERWISE NOTED, SHALL CONFORM TO ASTM A36.

ALL STAINLESS STEEL BARS AND SHAPES SHALL CONFORM TO ASTM A276, TYPE 316 ALLOY.

ALL NUTS, BOLTS AND WASHERS SHALL BE STAINLESS STEEL ASTM F593, TYPE 316 ALLOY.

MACHINE AND EYE BOLTS SHALL BE STAINLESS STEEL AND CONFORM TO ASTM A276, TYPE 316 ALLOY UNLESS OTHERWISE NOTED.

ANCHOR BOLTS SHALL BE STAINLESS STEEL TYPE 316 ALLOY AND CONFORM TO ASTM A276 AND A479.

WELDING RODS SHALL CONFORM TO AWS E70XX GRADE.

ALL STAINLESS STEEL WELDING SHALL CONFORM TO ASTM A530.

ALL WELDING OF WEATHERING STEEL SHALL BE ANSI / AASHTO / AWS D1.5-88. CONTRACTOR SHALL USE LOW-HYDROGEN ELECTRODES AND FOLLOW ALL MINIMUM PREHEAT SUGGESTIONS IN ANSI / AWS D1.1-92.

GALVANIZING SHALL BE BY THE HOT DIP METHOD ACCORDING TO ASTM SPECIFICATIONS A-123 AND A-153 UNLESS OTHERWISE NOTED. HOT DIP GALVANIZING SHALL BE IN A DRY KETTLE METHOD, WITH A ZINC-NICKEL ALLOY, IN ACCORDANCE WITH ASTM A 123, ASTM A 153 AND ASTM A385, AS APPLICABLE. GALVANIZING SHALL BE DONE WITH A NICKEL ENRICHMENT OF THE GALVANIZING TANK SUCH AS "NIGALV" OR APPROVED EQUAL

## ALUMINUM

THE DECKING FOR BOTH THE GANGWAY, RAMPS AND PLATFORMS SHALL BE NON-SKID WITH EITHER A RAISED RIB PROFILE WITH THE RIBS NO HIGHER THAN 1/4" AND PERPENDICULAR TO THE FLOW OF TRAFFIC, OR COVERED WITH A UNIFORM CARBORUMDUM SURFACE. SURFACES CAPABLE OF HAVING A SLOPE OF THAT IS STEEPER 1:12 SHALL HAVE A STATIC COEFFICIENT OF FRICTION OF 0.8 OR GREATER WHEN WET. SURFACES WHERE THE SLOPE WILL ALWAYS BE 1:12 OR LESS SHALL HAVE A STATIC COEFFICIENT OF FRICTION OF 0.5 OR GREATER WHEN WET.

ALL NUTS, BOLTS AND WASHERS SHALL BE STAINLESS STEEL ASTM F593 TYPE 316 ALLOY. NUTS SHALL BE SELF LOCKING.

EXPANSION JOINT MATERIAL BETWEEN ALUMINUM PLATFORMS SHALL BE CROSS LINKED POLYETHYLENE METASEALAS MANUFACTURED BY CAPITAL SERVICES OF NY, INC, TO THE DIMENSIONS SHOWN ON THE CONTRACT DOCUMENTS.

GANGWAY CONNECTION PINS AND SLEEVES SHALL BE STAINLESS STEEL AND MEET ASTM A269 TYPE 316 ALLOY.

## COATINGS

ALL COATINGS SHALL BE FROM THE SAME MANUFACTURER UNLESS OTHERWISE AGREED BY THE OWNER. ALL COATINGS SHALL BE TWO PART EPOXY, MIXED IMMEDIATELY PRIOR TO INSTALLATION.

ALL STEEL SHALL BE CLEANED AND PREPARED AS RECOMMENDED BY THE MANUFACTURER FOR EACH TYPE OF COATING PRIOR TO FABRICATION.

SANDBLASTING SHALL MEET THE REQUIREMENTS OF SSPC-SP10 "NEAR-WHITE BLAST CLEANING"

COATINGS SHALL MEET THE REQUIREMENTS OF SSPC-PS 13.01

COATING ON ALL STEEL PLATE AND SHAPES, ALL FIELD WELDED OR DAMAGED AREAS SHALL BE REPAIRED AS PER MANUFACTURERS RECOMMENDATIONS.

THE EXTERIOR OF THE BARGE, SIDES AND BOTTOM SHALL BE COATED WITH AMERCOAT 235 TWO PART EPOXY WITH 68% SOLIDS OR APPROVED EQUAL. THERE SHALL BE A MINIMUM OF TWO COATS WITH A FINAL DRY FILM THICKNESS OF 16 MILS (MINIMUM, NOT AVERAGE). THERE SHALL BE A STRIP COAT OVER SHARP EDGES, CUTOUTS AND WELDS. THERE SHALL BE CONTRASTING COLORS FOR EACH COAT WITH THE FINAL COLORS DARK GREY ABOVE THE WATERLINE AND LIGHT BLUE BELOW THE WATERLINE. ALL SURFACES MUST BE INSPECTED PRIOR TO COATING.

THE DECK OF THE BARGE SHALL BE COATED WITH AMERCOAT 238 TWO PART EPOXY WITH 77% SOLIDS OR APPROVED EQUAL. THERE SHALL BE A MINIMUM OF TWO COATS WITH A FINAL DRY FILM THICKNESS OF 16 MILS (MINIMUM, NOT AVERAGE). THE FINAL COAT SHALL CONTAIN AMERON FINE GRIT 886 ALUMINUM OR APPROVED EQUAL. THERE SHALL BE A STRIP COAT OVER SHARP EDGES, CUTOUTS AND WELDS. THERE SHALL BE CONTRASTING COLORS FOR EACH COAT WITH THE FINAL COLORS LIGHT GREY. ALL SURFACES MUST BE INSPECTED PRIOR TO COATING.

THE CONTRACTOR SHALL FOLLOW ALL RECOMMENDATIONS OF THE MANUFACTURER.

ALL BARGE DECKS OR OTHER STEEL WALKING SURFACES SHALL HAVE A LIGHT GRAY COLOR COATING AND SHALL HAVE A NON-SKID FINISH.

## STEEL BARGES

TACTILE WARNING STRIP SHALL BE DETECTABLE WARNING SURFACE AS MANUFACTURED BY AMS TACTILE SYSTEMS, LLC, STOUGHTON, MA OR APPROVED EQUAL.

ANODES SHALL BE ALOLINE GALVANIC ALUMINUM ANODES 29FM, MANUFACTURED BY FARWEST CORROSION, GARRDNA CA OR EQUAL. CONSUMPTION RATE OF 7.6 PONDS PER AMP YEAR, NO MERCURY ALLOWED. ALL ANODE CONNECTIONS SHALL BE BOLTED.

TYPE I BARGE UNITS SHALL HAVE 16 ANODES (MIN).  
TYPE II BARGE UNITS SHALL HAVE 12 ANODES (MIN).  
TYPE III BARGE UNITS SHALL HAVE 12 ANODES (MIN).  
TYPE IV BARGE UNITS SHALL HAVE 6 ANODES (MIN).

TYPE I PILE GUIDE SHALL HAVE 2 ANODES (MIN).  
TYPE II PILE GUIDE SHALL HAVE 2 ANODES (MIN).  
TYPE III PILE GUIDE SHALL HAVE 1 ANODES (MIN).

BOW LOADER UNITS SHALL HAVE 4 ANODES (MIN).

ALL BALLAST SHALL BE PLACED ON CCA TREATED TIMBER CROSS FRAMED TO PREVENT MOVEMENT OF THE TIMBER. TIMBER SHALL BE INSTALLED AND SECURED SUCH THAT MOVEMENT OF THE TIMBER IS NOT ALLOWED. NO DIRECT ATTACHMENT OF THE TIMBER TO THE BARGE SHALL BE ALLOWED. ALL TIMBER SHALL BE FASTENED USING STAINLESS STEEL THROUGH BOLTS WITH NO BOLT PROJECTIONS ON THE EXPOSED BALLAST DECK FACE.

BALLAST SHALL BE CONCRETE OR LEAD BLOCK.

## FENDER PANELS

THE RUBBER ELEMENTS USED SHALL BE CONE TYPE UNIT AS MANUFACTURED BY SUMITOMO. FENDER UNIT SHALL BE SUMITOMO PVT-600H, WITH CT2 TYPE RUBBER OR APPROVED EQUAL. FENDERS SHALL BE MOLDED RUBBER UNITS WITH METAL MOUNTING PLATES IMBEDDED IN AND BONDED TO THE ENDS TO CREATE AN INTEGRAL UNIT AT BOTH CONNECTION FACES. FENDER UNITS SHALL BE RESISTANT TO OZONE, SUNLIGHT, TEMPERATURE EXTREMES, MARINE GROWTH, WEAR AND ABRASION. EMBEDDED STEEL PLATES SHALL CONFORM TO ASTM A36 OR BETTER.

THE RUBBER PERFORMANCE CHARACTERISTICS SHALL BE:  
RATED DEFLECTION 57.5% - REACTION LOAD 25.7 ton / ENERGY ABSORPTION 6.4 ton-M  
MAXIMUM DEFLECTION 60% - REACTION LOAD 28.2 ton / ENERGY ABSORPTION 6.8 ton-M

FENDER PANEL CHAINS SHALL BE GALVANIZED, SPECTRUM 4 HIGH STRENGTH CHAIN AS MANUFACTURED BY CROSBY GROUP OR APPROVED EQUAL HAVING A SAFE WORKING LOAD CAPACITY OF 18,500 POUNDS.

CONNECTING LINKS SHALL BE OF THE SIZE SHOWN ON THE PLAN AND SHALL BE LOK-A-LOY-6 CONNECTING LINKS AS MANUFACTURED BY CROSBY GROUP OR APPROVED EQUAL HAVING A SAFE WORK LOAD CAPACITY OF 23,000 POUNDS.

RUBBER FENDER FACING: MATERIAL SHALL BE A SOLID RUBBER, NATURAL OR SYNTHETIC AND CONFORM TO ASTM D2000 CALLOUT 3BA720A14B13C12EA14F17G11 (G11≥250 LB/SQ IN) AS MANUFACTURED BY MARITIME INTERNATIONAL, INC. OR APPROVED EQUAL.

FENDER PANEL PERIMETER: PERIMETER OF PANEL SHALL BE COVERED WITH UHMW-PE.

## CONCRETE WORKS

ALL REINFORCEMENT SHALL BE NEW DEFORMED BILLET STEEL BARS, GRADE 60, AND GALVANIZED IN ACCORDANCE WITH ASTM A-123. REINFORCEMENT ACCESSORIES SHALL BE DIELECTRIC COATED STEEL OR APPROVED PLASTIC. FORM COATINGS SHALL BE NON-GRAIN RAINING AND NON-STAINING TYPE THAT DO NOT LEAVE RESIDUE.

THERE ARE TWO TYPES OF AGGREGATE FOR THE PROJECT. IMPORTED AGGREGATE SHALL MEET ASTM C33 FOR FINE COARSE AGGREGATES. LOCAL BERMUDA AGGREGATE SHALL BE APPROVED BY THE OWNER PRIOR TO USE.

NO WATER SHALL BE ADDED AT THE SITE DURING PLACEMENT OPERATIONS. ALL CONCRETE SHALL MEET SLUMP REQUIREMENTS FOR THE TYPE AND LOCATION.  
AIR ENTRAINMENT SHALL BE MAINTAINED AT 3% - 5% FOR ALL CONCRETE WORKS.  
TYPE A GROUT IS CEMENTATIOUS GROUT THAT IS NON-METALLIC AND CONTAINS NO CHLORIDE, TYPE B SHALL BE A HIGH STRENGTH, NON-SHRINK GROUT WITH SALTWATER RESISTANCE SUCH AS FIVE STAR GROUT 120.  
CONSTRUCTION JOINTS SHALL BE A MAXIMUM OF 40 APART.  
EXPANSION JOINTS SHALL INCLUDE A JOINT FILLER, BOND BREAKER AND JOINT SEALANT.  
CONCRETE SHALL BE CURED FOR 7 DAYS AND KEEP IN A MOIST CONDITION FOR THIS ENTIRE TIME.

## PILE JACKETS

ALL CONCRETE FOR PILE JACKETING SHALL BE 4000 PSI CONCRETE WITH 3/8" (3/4" ALLOWED IF LARGER PIPE USED FOR PLUMBING) IMPORTED AGGREGATE.  
PILE JACKETS SHALL BE 1/4" THICK MINIMUM FIBERGLASS JACKET THAT NEST ON EACH TO PROVIDE THE SUFFICIENT LENGTH OF JACKET.  
THE BOTTOM OF THE FORM REQUIRES A 200MM EPOXY GROUT PLUG THAT HAS FULLY CURED PRIOR TO PLACEMENT OF CONCRETE.  
THE JACKETS SHALL HAVE REINFORCING BANDS AS RECOMMENDED BY THE MANUFACTURER OF THE JACKET.

## HOIST SYSTEM

THE MECHANICAL WINCH SHALL BE JEAMAR CMA HEAVY DUTY SEAWORTHY ALUMINUM MODEL CMA 1760.  
THE ELECTRICAL WINCH SHALL BE THE JEAMAR NLS2000 HEAVY DUTY LIFTING WINCH, SINGLE PHASE. THE WIRE ROPE SHALL BE THE STEEL WIRE ROPE, 6X37 IWRC, EIPS AS SUPPLIED BY JEAMAR WITH THE WINCHES.  
ALL SHEAVES AND BLOCKS SHALL BE JEAMAR UNITS THAT ARE SEALED AND SELF LUBRICATING. REMOTE WINCH CONTROLLER AND ELECTRICAL BOX SHALL BE WEATHER TIGHT, LOCKING AS SUPPLIED BY JEAMAR WITH THE UNITS.  
ALL CABLE DIRECTED TO BE SUBAQUEOUS SHALL BE MINING CABLE - 600/2000 VOLT TYPE G OR GC THREE CONDUCTOR ROUND CABLE.

## MISCELLANEOUS ITEMS

ALL FRICTION SURFACES SHALL HAVE A DYNAMIC COEFFICIENT OF FRICTION OF 0.10 - 0.14 (DRY). MATERIAL SHALL HAVE A DENSITY OF 0.93 g/cm<sup>3</sup>, MINIMUM TENSILE STRENGTH OF 4000 psi, ABRASION INDEX OF 10 (SAND SLURRY), A SAND ON WHEEL INDEX OF 100cc (ASTM G65) AND A DUROMETER VALUE OF 67 (ASTM D-2240).

ALL HATCHES SHALL BE REMOVABLE WITH A MINIMUM OPENING OF 0.680M CLEAR. HATCHES SHALL BE WATERTIGHT WITH A NEOPRENE GASKET THAT CONFORMS TO MIL SPEC MIL R-6855 CLASS 2 NEOPRENE GRADE 60. HATCH SHALL BE SECURED WITH STAINLESS STEEL SOCKET SCREWS, FLUSH TO THE HATCH.

ALL DISSIMILAR METALS SHALL BE SEPARATED WITH PLASTIC SHEETS OR BUSHINGS NO LESS THAN 1.59MM (1/16") THICK. PLASTIC PADS SHALL BE PLACED UNDER ALL ALUMINUM BASE PLATES AND BUSHINGS INSTALLED BETWEEN ALL STAINLESS STEEL STUDS. THE SEPARATION MATERIAL SHALL BE NYLATRON-GS PLASTIC CONFORMING TO MILITARY SPECIFICATION MIL-P-15035.

RAILING SHALL BE 1 1/2" I.P.S. SCHEDULE 40 INTER-RAIL TYPE WITH HEAVY DUTY BASE PLATES.

## THE MINISTRY OF WORKS AND ENGINEERING

P.O. Box HM525 Hamilton HMCK Bermuda  
Phone: (441)295-5151

ENGINEERING and  
OPERATIONS DIVISION  
Fax: (441)295-0170

## Structures Section

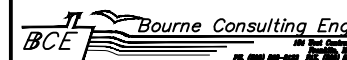

GENERAL NOTES:

ISSUED FOR: REFERENCE ONLY 2016 09 07

### AMENDMENTS:

NO:	REVISION	APP	DATE:
▲	Revised as noted	RJT	14/08/01
▲	Revised as noted	RRB	04/01/02
▲	Revised as noted	MAM	2016 09 0

SCALE: NONE

### SURVEY

PREPARED BY: DATE:

### DESIGN

PREPARED BY: DATE:

DRG 16/03/01

CHECKED BY: DATE:

RRB 16/03/01

### DRAWING

PREPARED BY: DATE:

BAP 16/03/01

CHECKED BY: DATE:

DRG 16/03/01

APPROVED BY:

RRB

PROJECT NUMBER:

61/01/01

PROJECT NAME:

REPLACEMENT FERRY PROJE  
PHASE I  
DOCK CONSTRUCTION

DRAWING FILE NO: ACAD R-14

T-2 gen notes.dwg

SHEET TITLE:

GENERAL NOTES

SHEET NUMBER:

61/01/01/T2

REVISION

▲

REFERENCE ONLY

Reference Drawings

Structures Section

GENERAL NOTES:  
WTBH - WATER TIGHT BULKHEAD

ISSUED FOR: REFERENCE ONLY 2016 09 07

AMENDMENTS:

NO:	REVISION	APP	DATE:
B	REVISIONS AS NOTED	RRB	04/01/02
C	REFERENCE ONLY	MAM	2016 09 07

SCALE: AS NOTED

SURVEY

PREPARED BY:	DATE:
BAP	23/05/01
CHECKED BY:	DATE:
RRB	23/05/01

DESIGN

PREPARED BY:	DATE:
JSK	23/05/01
CHECKED BY:	DATE:
RRB	23/05/01

APPROVED BY:

RRB

PROJECT NUMBER:

61/01/01

PROJECT NAME:

REPLACEMENT FERRY PROJECT  
PHASE 1  
DOCK CONSTRUCTION

DRAWING FILE NO: ACAD R-14  
T-3 STD Barge Units.dwg

SHEET TITLE:  
STANDARD  
BARGE UNITS

SHEET NUMBER: 61/01/01/T3

REVISION  
A

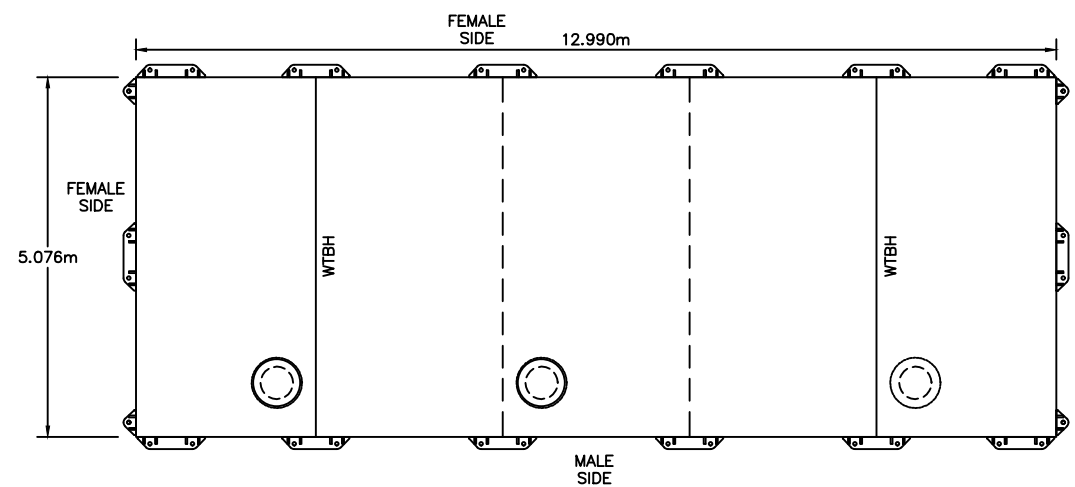

APPROXIMATE WEIGHT  
PER FABRICATOR: 58,388 lbs

**A**  
T3  
**TYPE I BARGE**  
SCALE: 1 : 50

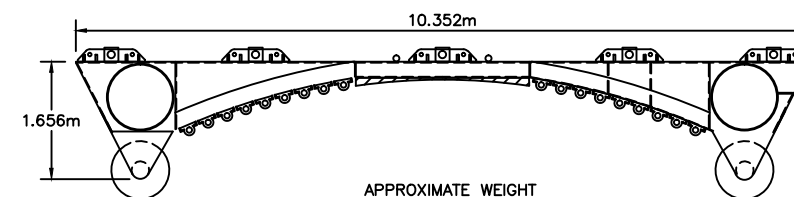
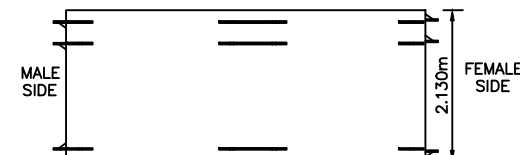

APPROXIMATE WEIGHT  
PER FABRICATOR: 28,500 lbs

**B**  
T3  
**BOW LOADER UNIT**  
SCALE: 1 : 50

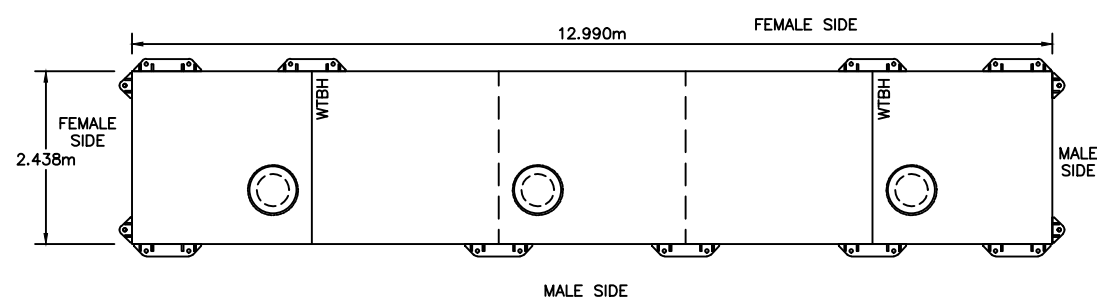

APPROXIMATE WEIGHT  
PER FABRICATOR: 36,476 lbs

**C**  
T3  
**TYPE II BARGE**  
SCALE: 1 : 50

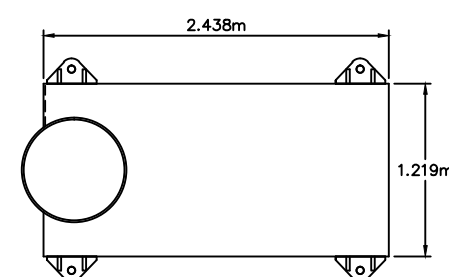
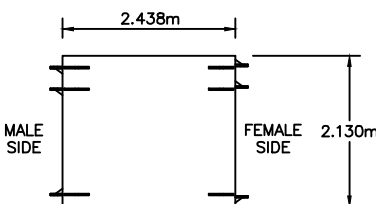

APPROXIMATE WEIGHT  
PER FABRICATOR: 4,950 lbs

**D**  
T3  
**TYPE I PILE GUIDE**  
SCALE: 1 : 25

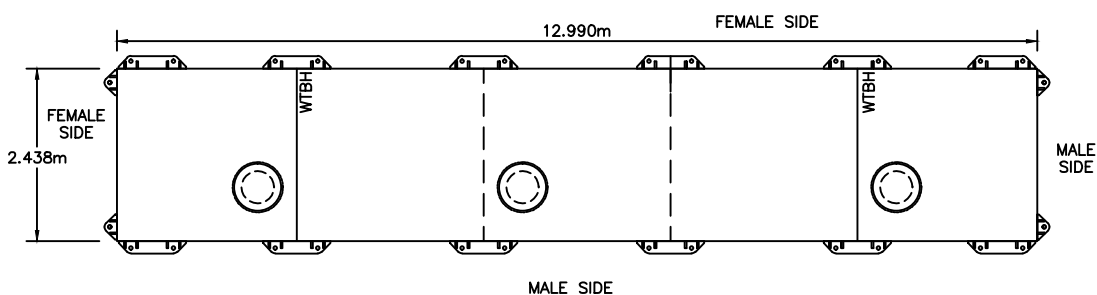
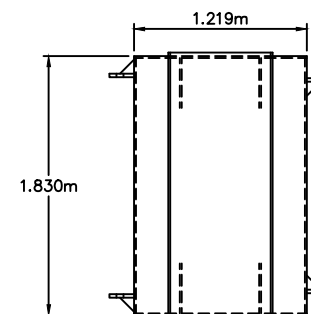

APPROXIMATE WEIGHT  
PER FABRICATOR: 32,802 lbs

**E**  
T3  
**TYPE III BARGE**  
SCALE: 1 : 50

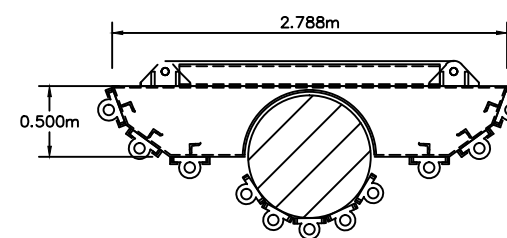
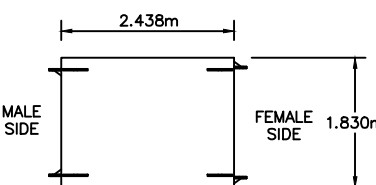

APPROXIMATE WEIGHT: 5,890 lbs  
PER FABRICATOR: 5,434 lbs

**G**  
T3  
**TYPE II PILE GUIDE**  
SCALE: 1 : 25

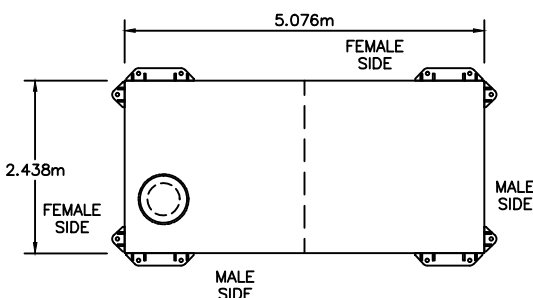
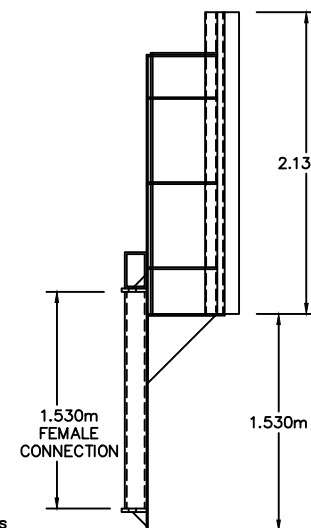

APPROXIMATE WEIGHT  
PER FABRICATOR: 13,948 lbs

**F**  
T3  
**TYPE IV BARGE**  
SCALE: 1 : 50

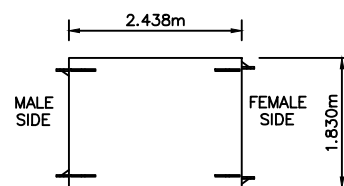

REFERENCE ONLY

Reference Drawings

GENERAL NOTES:

ISSUED FOR: REFERENCE ONLY 2016 09 07

AMENDMENTS:

NO:	REVISION	APP	DATE:
△	HIGH HMS FENDER	RRB	04/01/02
△	REFERENCE ONLY	MAM	2016 09 07

SCALE: AS NOTED

SURVEY

PREPARED BY: DATE:

DESIGN

PREPARED BY: BAP DATE: 23/05/01  
CHECKED BY: RRB DATE: 23/05/01

DRAWING

PREPARED BY: JSK DATE: 23/05/01  
CHECKED BY: RRB DATE: 23/05/01

APPROVED BY:  
RRB

PROJECT NUMBER:  
61/01/01

PROJECT NAME:

REPLACEMENT FERRY PROJECT  
PHASE 1  
DOCK CONSTRUCTION

DRAWING FILE NO: ACAD R-14  
T-4 STD Barge Attachments.dwg

SHEET TITLE:

STANDARD  
BARGE ATTACHMENTS

SHEET NUMBER: 13/01/01/T4 REVISION:

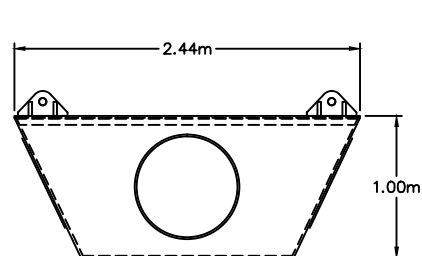

2 PINS REQ'D-LENGTH VARIES

**A**  
T4  
TYPE III PILE GUIDE  
SCALE: 1 : 25

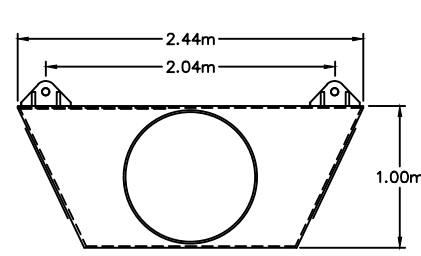
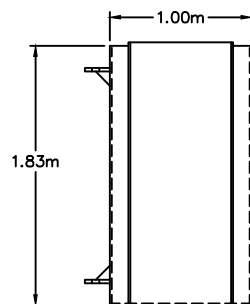

2 LONG PINS REQ'D

**B**  
T4  
TYPE IV PILE GUIDE  
SCALE: 1 : 25

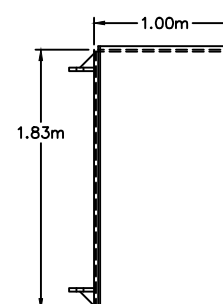

**C**  
T4  
WALL FENDER  
SCALE: 1 : 25

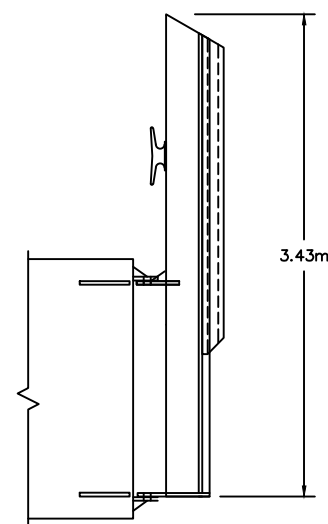
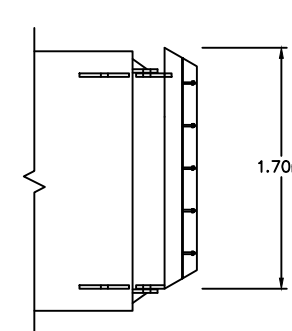

**D**  
T4  
2 SHORT PINS REQ'D  
HIGH FENDER TYPE HM  
SCALE: 1 : 25

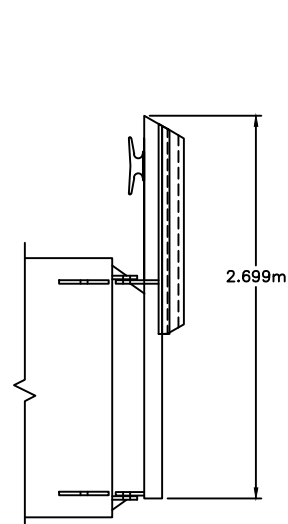

**E**  
T4  
2 SHORT PINS REQ'D  
LOW FENDER TYPE LM  
SCALE: 1 : 25

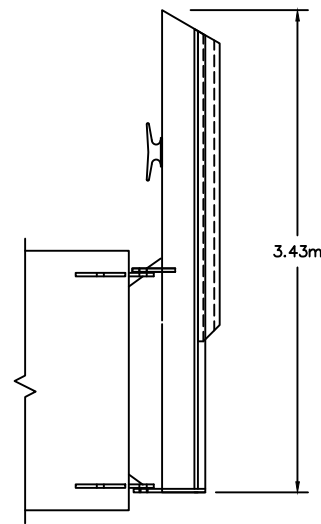

**F**  
T4  
2 SHORT PINS REQ'D  
HIGH FENDER TYPE HF  
SCALE: 1 : 25

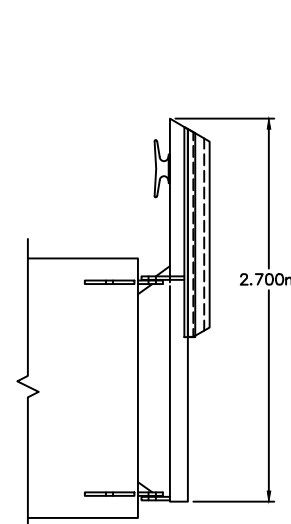

**G**  
T4  
2 SHORT PINS REQ'D  
LOW FENDER TYPE LF  
SCALE: 1 : 25

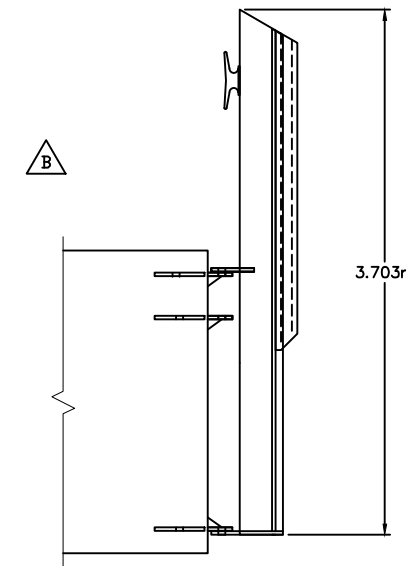

**H**  
T4  
2 LONG PINS REQ'D  
HIGH FENDER TYPE HMS  
SCALE: 1 : 25

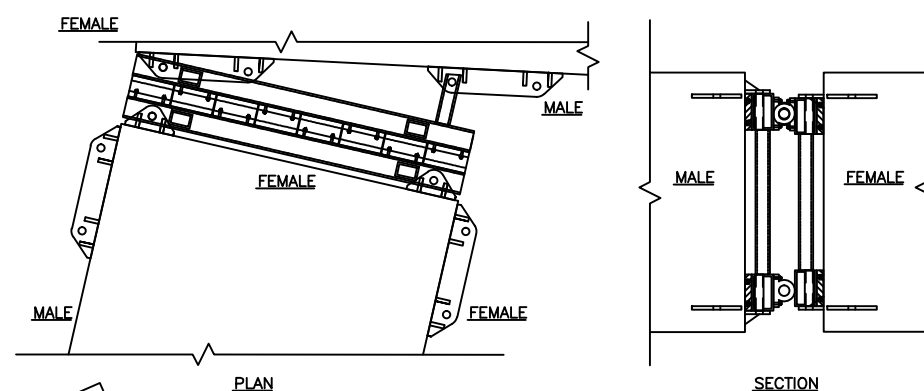

**I**  
T4  
BARGE CONNECTION - DETAIL  
SCALE: 1 : 25

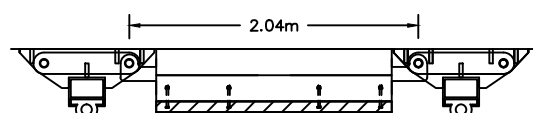

**J**  
T4  
TRANSITION ASSEMBLY  
SCALE: 1 : 25

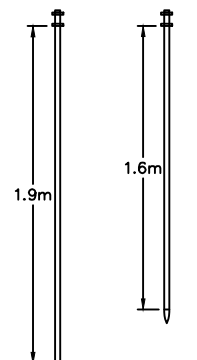
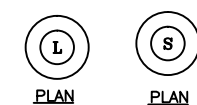

LONG PIN- ELEVATION  
SHORT PIN- ELEVATION  
**K**  
T4  
PIN DETAIL  
SCALE: 1 : 20

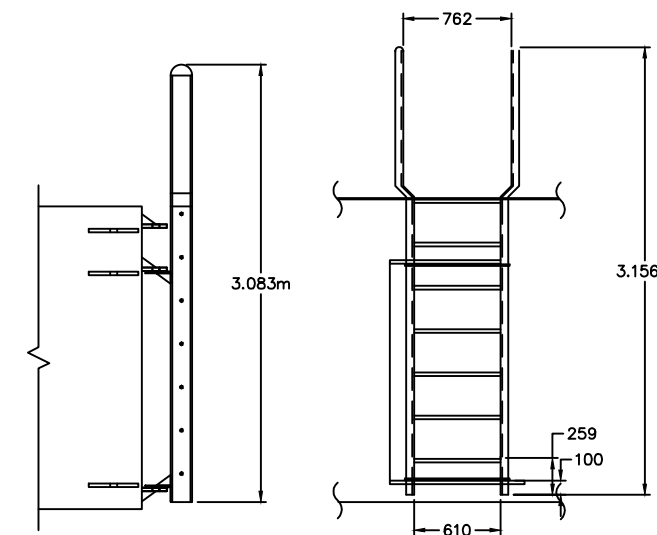

**L**  
T4  
LADDER  
SCALE: 1 : 25

Reference Drawings

REFERENCE ONLY

Structures Section

GENERAL NOTES:

ISSUED FOR: REFERENCE ONLY 2016 09 07

AMENDMENTS:

NO:	REVISION	APP	DATE:

SCALE: 1 : 50

SURVEY

PREPARED BY: DATE:

DESIGN

PREPARED BY: DATE:  
BAP 23/05/01  
CHECKED BY: DATE:  
RRB 23/05/01

DRAWING

PREPARED BY: DATE:  
JSK 23/05/01  
CHECKED BY: DATE:  
RRB 23/05/01

APPROVED BY:  
RRB

PROJECT NUMBER:  
61/01/01

PROJECT NAME:

REPLACEMENT FERRY PROJECT  
PHASE 1  
DOCK CONSTRUCTION

DRAWING FILE NO: ACAD R-14  
T-5 STD Aluminum Platforms.dwg

SHEET TITLE:

STANDARD ALUMINUM  
PLATFORMS

SHEET NUMBER: REVISION  
61/01/01/T5

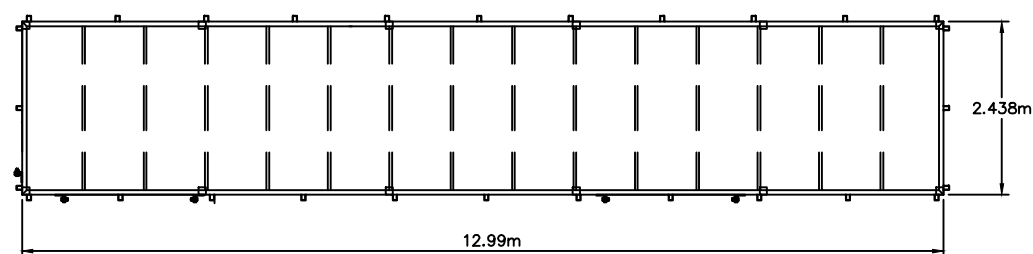

**A**  
T5  
TYPE A PLATFORM  
SCALE: 1 : 50

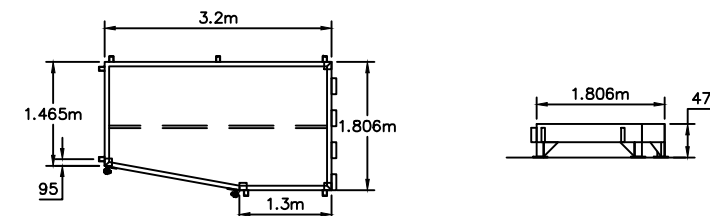
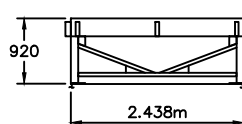

**B**  
T5  
HT-TYPE 2 PLATFORM  
SCALE: 1 : 50

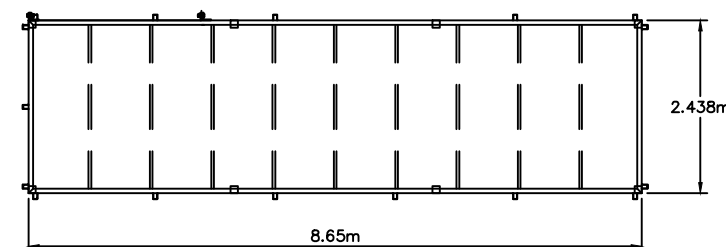

**C**  
T5  
TYPE B PLATFORM  
SCALE: 1 : 50

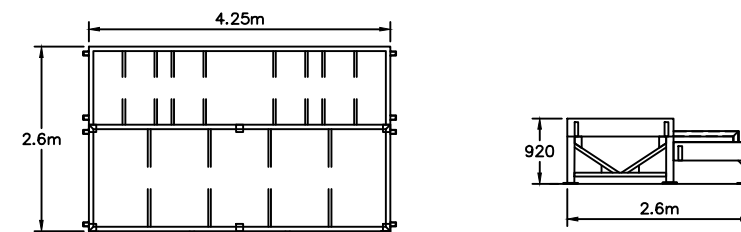
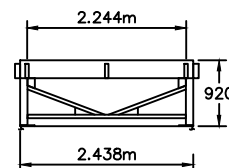

**D**  
T5  
DY-TYPE 1 PLATFORM  
SCALE: 1 : 50

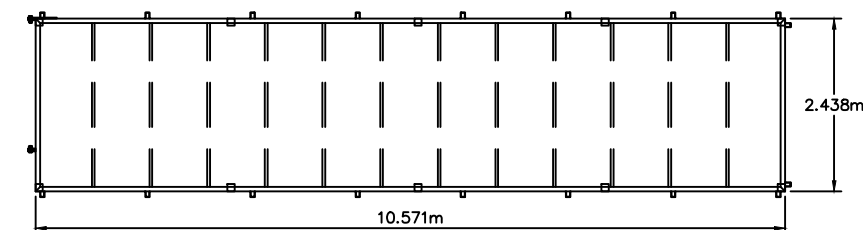

**E**  
T5  
HD-TYPE 1 PLATFORM  
SCALE: 1 : 50

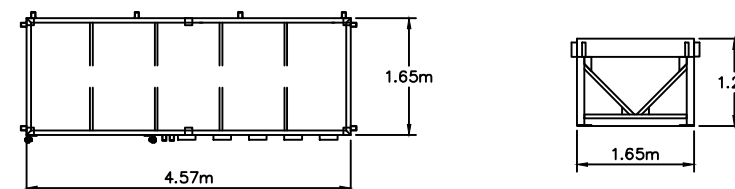
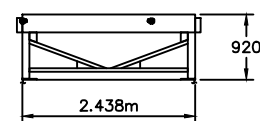

**F**  
T5  
DY-TYPE 2 PLATFORM  
SCALE: 1 : 50

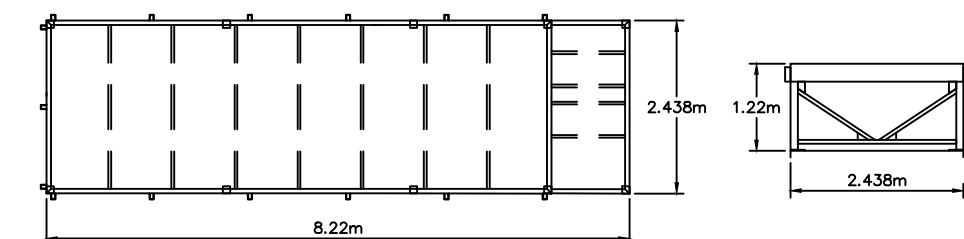

**G**  
T5  
HD-TYPE 2 PLATFORM  
SCALE: 1 : 50

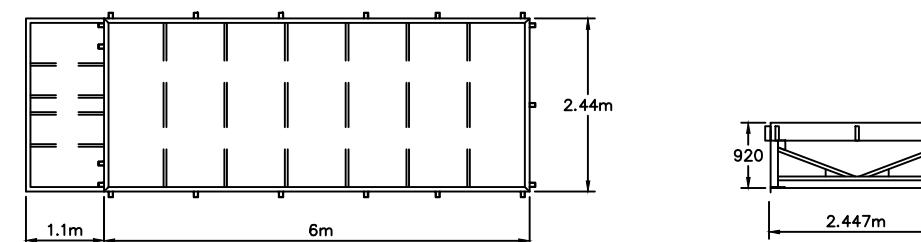

**H**  
T5  
StG-TYPE 1 PLATFORM  
SCALE: 1 : 50

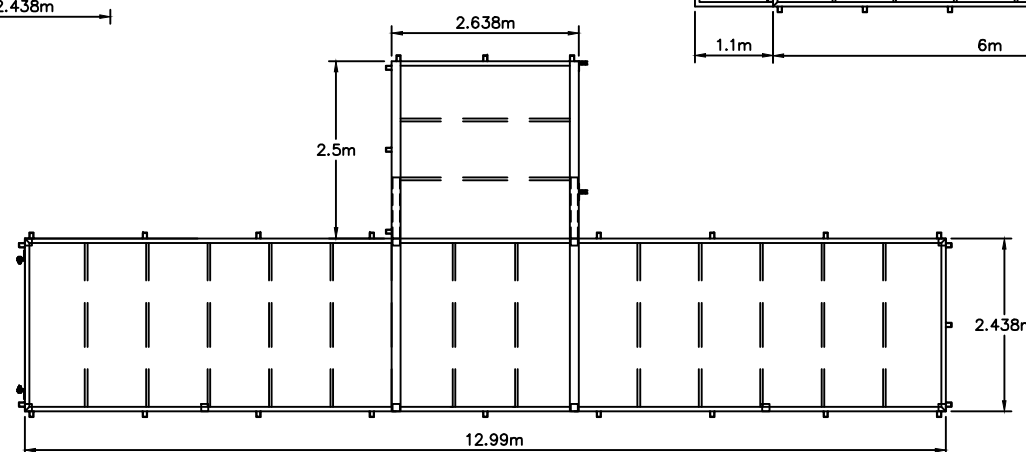

**I**  
T5  
HT-TYPE 1 PLATFORM  
SCALE: 1 : 50

REFERENCE ONLY

Reference Drawings

Structures Section



GENERAL NOTES:

ISSUED FOR: REFERENCE ONLY 2016 09 07

AMENDMENTS:

NO.	REVISION	APP	DATE:

SCALE: 1 : 25

SURVEY

PREPARED BY: DATE:

DESIGN

PREPARED BY: BAP DATE: 23/05/01

CHECKED BY: RRB DATE: 23/05/01

DRAWING

PREPARED BY: JSK DATE: 23/05/01

CHECKED BY: RRB DATE: 23/05/01

APPROVED BY:  
RRB

PROJECT NUMBER:  
61/01/01

PROJECT NAME:

REPLACEMENT FERRY PROJECT  
PHASE 1  
DOCK CONSTRUCTION

DRAWING FILE NO: ACAD R-14

SHEET TITLE:

STANDARD ALUMINUM  
GANGWAYS & RAMPS

SHEET NUMBER: REVISION

61/01/01/T6

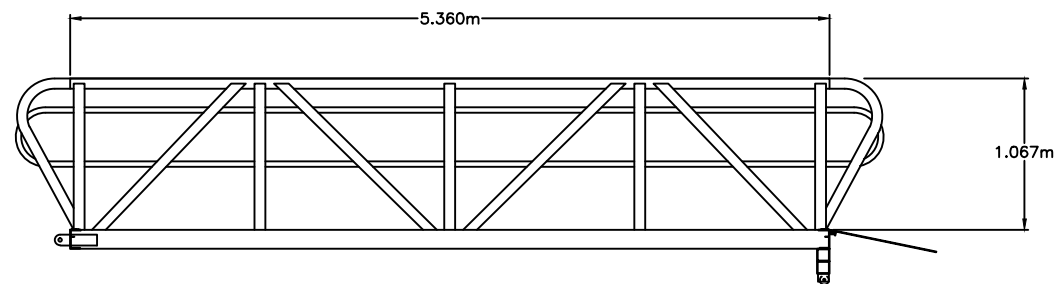

**A** TYPE I GANGWAY - ELEVATION  
T6 SCALE: 1 : 25

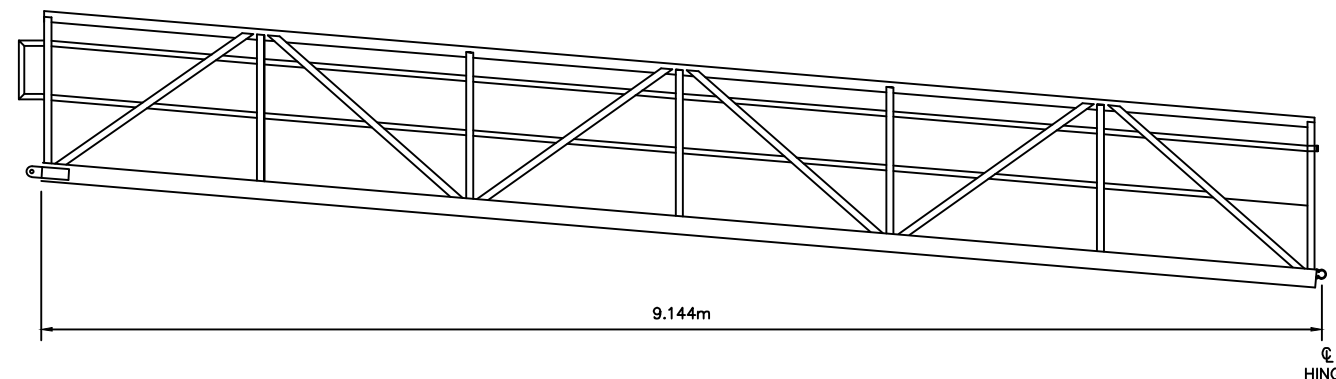

**B** TYPE A RAMP - ELEVATION  
T6 SCALE: 1 : 25

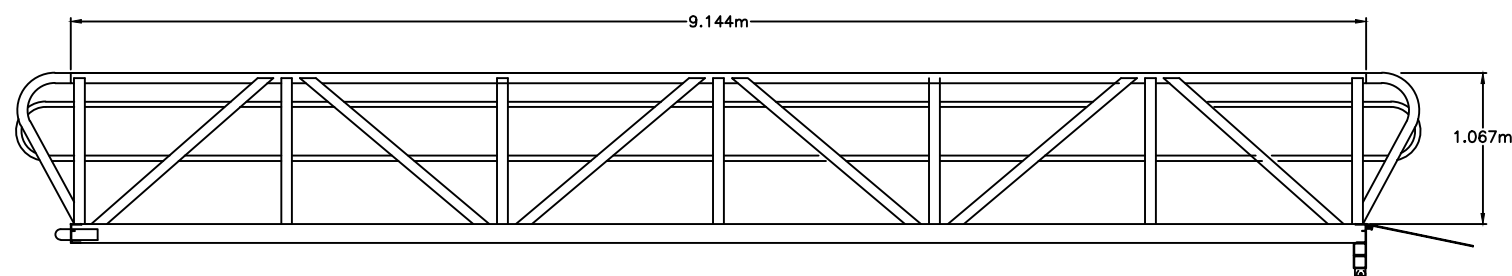

**C** TYPE II GANGWAY - ELEVATION  
T6 SCALE: 1 : 25

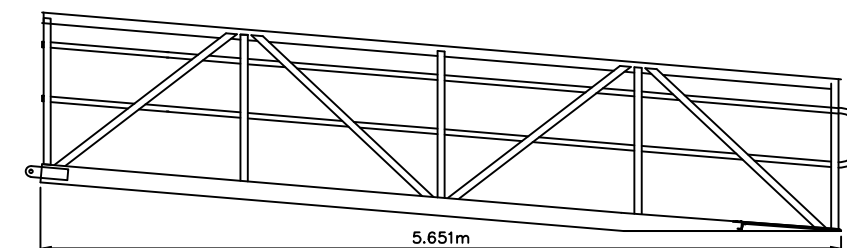

**D** HT-TYPE 1 RAMP - ELEVATION  
T6 SCALE: 1 : 25

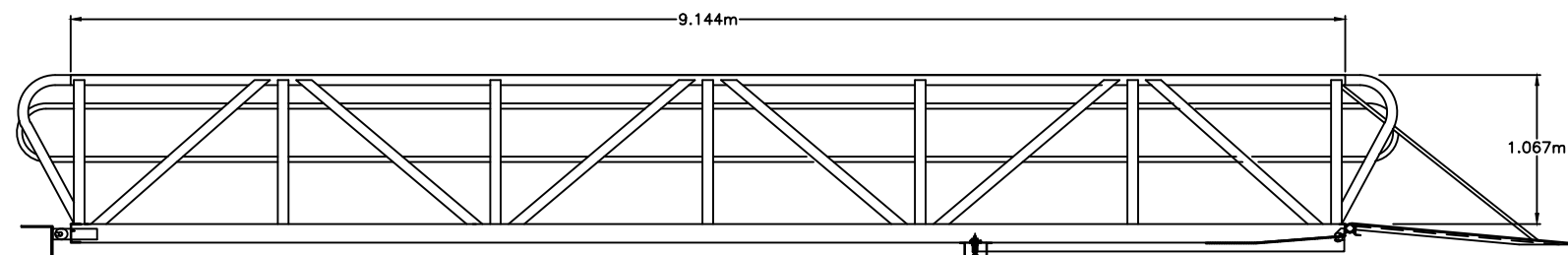

**E** TYPE III GANGWAY - ELEVATION  
T6 SCALE: 1 : 25

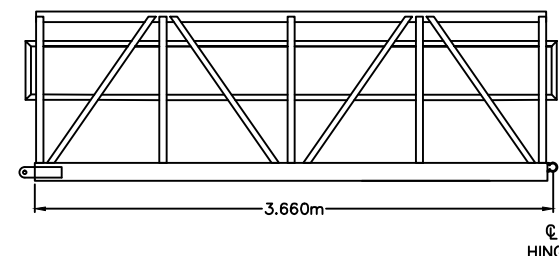

**F** DY-TYPE 1 RAMP - ELEVATION  
T6 SCALE: 1 : 25

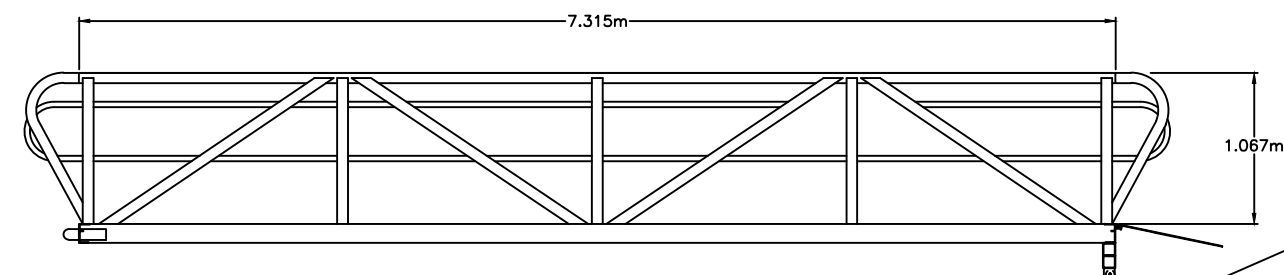

**G** TYPE IV GANGWAY - ELEVATION  
T6 SCALE: 1 : 25

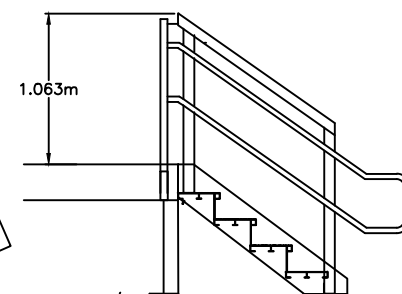

**H** STAIRS  
T6 SCALE: 1 : 25

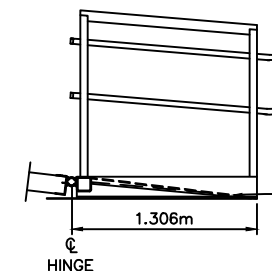

**I** TRANSITION RAMP - ELEVATION  
T6 SCALE: 1 : 25

REFERENCE ONLY

Reference Drawings

Structures Section



- GENERAL NOTES:
1. COORDINATES BASED ON BNG 2000.
  2. ALL ELEVATIONS ARE IN METERS BASED ON ORDNANCE DATUM.
  3. ALL DISTANCES ARE IN METERS.
  4. SURVEY CONTROL SHALL BE PROVIDED TO THE CONTRACTOR BY THE OWNER.

ISSUED FOR: CONSTRUCTION 14/08/01

AMENDMENTS:

NO:	REVISION	APP	DATE:
Δ	BARGES II & IV	RRB	04/01/02

SCALE: 1 : 100

SURVEY  
PREPARED BY: DATE:

DESIGN  
PREPARED BY: DATE: 23/05/01  
BAP  
CHECKED BY: DATE: 23/05/01  
RRB

DRAWING  
PREPARED BY: DATE: 23/05/01  
JSK  
CHECKED BY: DATE: 23/05/01  
RRB

APPROVED BY:  
RRB  
PROJECT NUMBER:  
61/01/01

PROJECT NAME:  
**HAMILTON TERMINAL  
REPLACEMENT FERRY PROJECT  
PHASE 1  
DOCK CONSTRUCTION**

**#1 POINT PLEASANT ROAD  
PEMBROKE PARISH**  
DRAWING FILE NO: ACAD R-14  
HT-4\_Site-Layout.dwg

SHEET TITLE:  
**SITE  
PLAN**

SHEET NUMBER: 3/26/02/HT2 REVISION: Δ

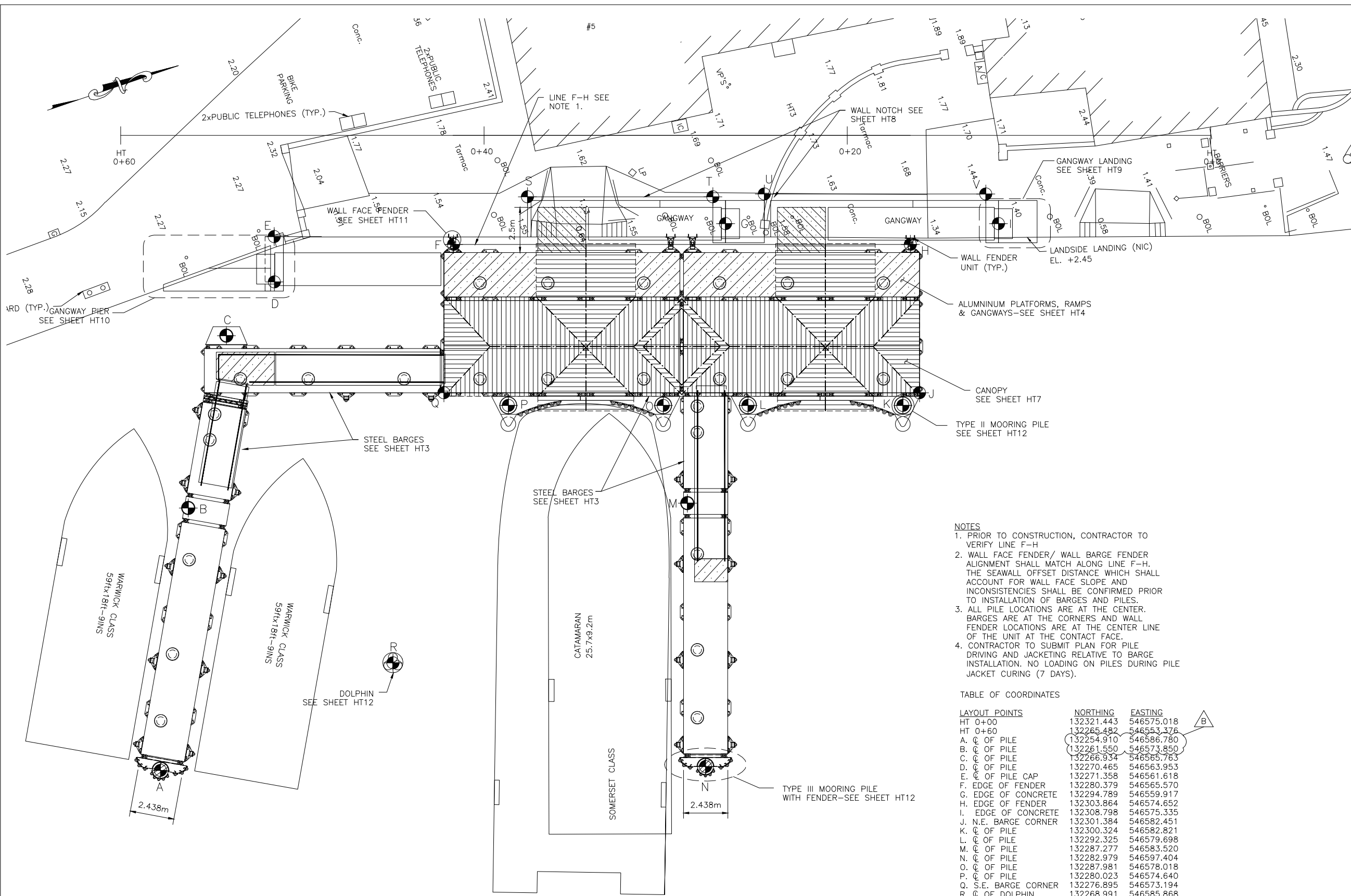

GENERAL LAYOUT PLAN

- NOTES
1. PRIOR TO CONSTRUCTION, CONTRACTOR TO VERIFY LINE F-H
  2. WALL FACE FENDER/ WALL BARGE FENDER ALIGNMENT SHALL MATCH ALONG LINE F-H. THE SEAWALL OFFSET DISTANCE WHICH SHALL ACCOUNT FOR WALL FACE SLOPE AND INCONSISTENCIES SHALL BE CONFIRMED PRIOR TO INSTALLATION OF BARGES AND PILES.
  3. ALL PILE LOCATIONS ARE AT THE CENTER. BARGES ARE AT THE CORNERS AND WALL FENDER LOCATIONS ARE AT THE CENTER LINE OF THE UNIT AT THE CONTACT FACE.
  4. CONTRACTOR TO SUBMIT PLAN FOR PILE DRIVING AND JACKETING RELATIVE TO BARGE INSTALLATION. NO LOADING ON PILES DURING PILE JACKET CURING (7 DAYS).

TABLE OF COORDINATES

LAYOUT POINTS	NORTHING	EASTING
HT 0+00	132321.443	546575.018
HT 0+60	132265.482	546553.376
A. C. OF PILE	132254.910	546586.780
B. C. OF PILE	132261.550	546573.850
C. C. OF PILE	132266.934	546565.763
D. C. OF PILE	132270.465	546563.953
E. C. OF PILE CAP	132271.358	546561.618
F. EDGE OF FENDER	132280.379	546565.570
G. EDGE OF CONCRETE	132294.789	546559.917
H. EDGE OF FENDER	132303.864	546574.652
I. EDGE OF CONCRETE	132308.798	546575.335
J. N.E. BARGE CORNER	132301.384	546582.451
K. C. OF PILE	132300.324	546582.821
L. C. OF PILE	132292.325	546579.698
M. C. OF PILE	132287.277	546583.520
N. C. OF PILE	132282.979	546597.404
O. C. OF PILE	132287.981	546578.018
P. C. OF PILE	132280.023	546574.640
Q. S.E. BARGE CORNER	132276.895	546573.194
R. C. OF DOLPHIN	132268.991	546585.868
S. COR. OF CONCRETE	132285.149	546564.603
T. COR. OF CONCRETE	132294.670	546568.285
U. COR. OF CONCRETE	132297.365	546569.167
V. COR. OF CONCRETE	132308.732	546573.563

⊙ A - LAYOUT POINT

SCALE: 1 : 100

CONSTRUCTION  
Reference Drawings

Structures Section



- GENERAL NOTES:
1. COORDINATES BASED ON BNG 2000.
  2. ALL ELEVATIONS ARE IN METERS BASED ON ORDNANCE DATUM.
  3. ALL DISTANCES ARE IN METERS.
  4. SURVEY CONTROL SHALL BE PROVIDED TO THE CONTRACTOR BY THE OWNER.

ISSUED FOR: CONSTRUCTION 14/08/01

AMENDMENTS:

NO:	REVISION	APP	DATE:
A	BARGES II & IV	RRB	04/01/02

SCALE: 1 : 100

SURVEY  
PREPARED BY: DATE:

DESIGN  
PREPARED BY: DATE: 23/05/01  
BAP  
CHECKED BY: DATE: 23/05/01  
RRB

DRAWING  
PREPARED BY: DATE: 23/05/01  
JSK  
CHECKED BY: DATE: 23/05/01  
BAP

APPROVED BY:  
RRB

PROJECT NUMBER:  
61/01/01

PROJECT NAME:  
HAMILTON TERMINAL  
REPLACEMENT FERRY PROJECT  
PHASE 1  
DOCK CONSTRUCTION

#1 POINT PLEASANT ROAD  
PEMBROKE PARISH

DRAWING FILE NO: ACAD R-14  
HT-3\_Barge-assembly.dwg

SHEET TITLE:  
BARGE ASSEMBLY  
PLAN

SHEET NUMBER:  
13/26/02/HT3

REVISION  
B

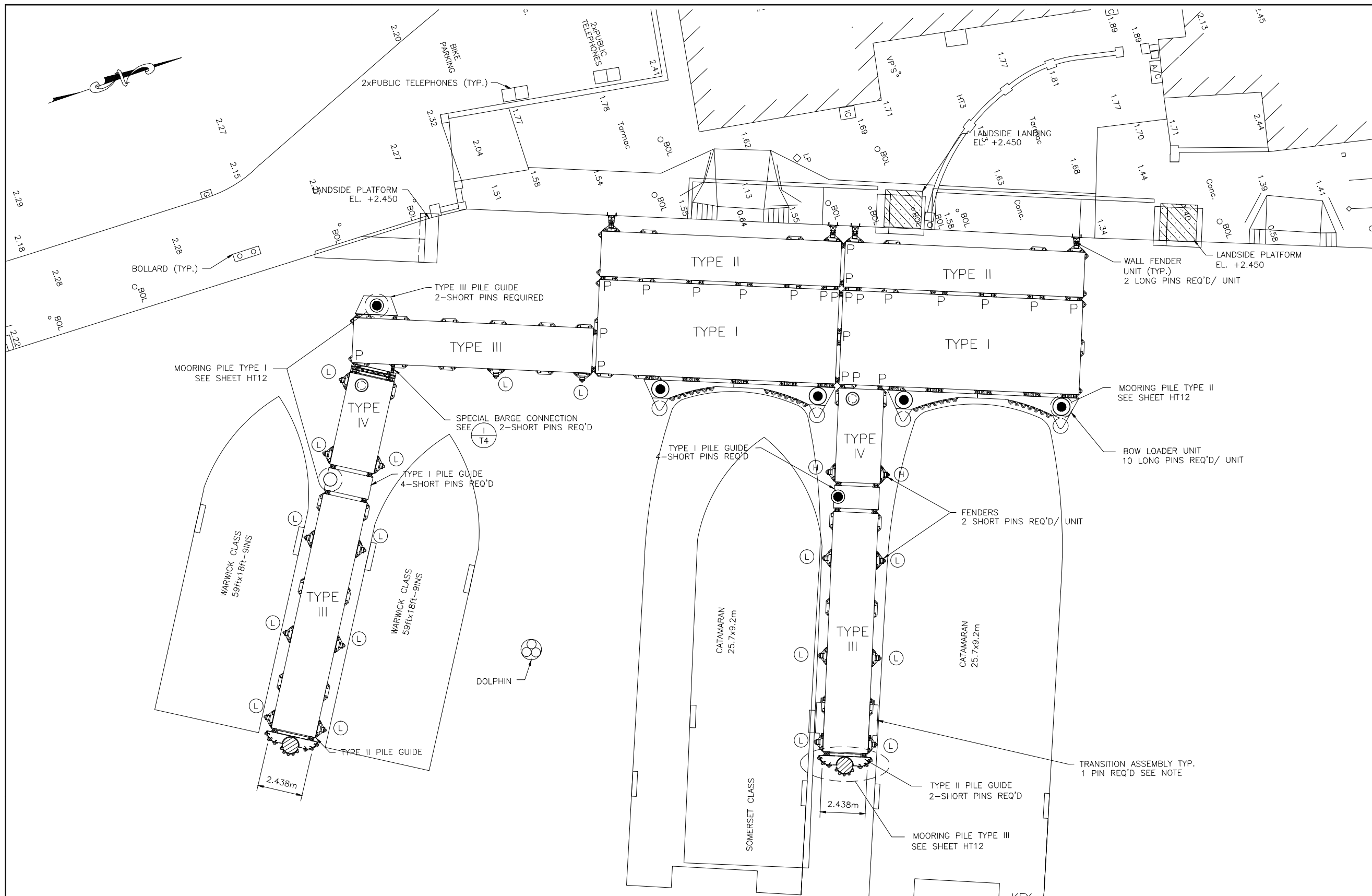

BARGE LAYOUT

- (L) LOW FENDER - SEE SHEET T4.
- (H) HIGH FENDER - SEE SHEET T4.
- P-BARGE TO BARGE PIN REQUIRED

NOTE: 1. SEE SHEETS T3 FOR BARGE UNITS.  
2. SEE SHEETS T4 FOR PILE GUIDE UNITS.  
3. TRANSITION ASSEMBLY TO USE COMMON PIN W/ BARGE FENDER.

CONSTRUCTION



Reference Drawings



Structures Section

**BCE** Bourne Consulting Engin  
184 West Central Street  
Franklin, MA 02003  
TEL: (508) 528-8133 FAX: (508) 520-887

GENERAL NOTES:

1. COORDINATES BASED ON BNG 2000.
2. ALL ELEVATIONS ARE IN METERS BASED ON ORDNANCE DATUM.
3. ALL DISTANCES ARE IN METERS.
4. SURVEY CONTROL SHALL BE PROVIDED TO THE CONTRACTOR BY THE OWNER.

ISSUED FOR: CONSTRUCTION 14/08/01

AMENDMENTS:

NO:	REVISION	APP	DATE:
A	BARGES II & IV	RRB	04/01/02

SCALE: 1 : 100

SURVEY

PREPARED BY: DATE:

DESIGN

PREPARED BY: BAP DATE: 23/05/01  
CHECKED BY: RRB DATE: 23/05/01

DRAWING

PREPARED BY: JSK DATE: 23/05/01  
CHECKED BY: BAP DATE: 23/05/01

APPROVED BY:  
RRB

PROJECT NUMBER:  
61/01/01

PROJECT NAME:  
**HAMILTON TERMINAL  
REPLACEMENT FERRY PROJECT  
PHASE 1  
DOCK CONSTRUCTION**

**#1 POINT PLEASANT ROAD  
PEMBROKE PARISH**

DRAWING FILE NO: ACAD R-14  
HT-4\_Alum-Assembly.dwg

SHEET TITLE:  
**ALUMINUM  
ASSEMBLY PLAN**

SHEET NUMBER: 13/26/02/HT4  
REVISION: A

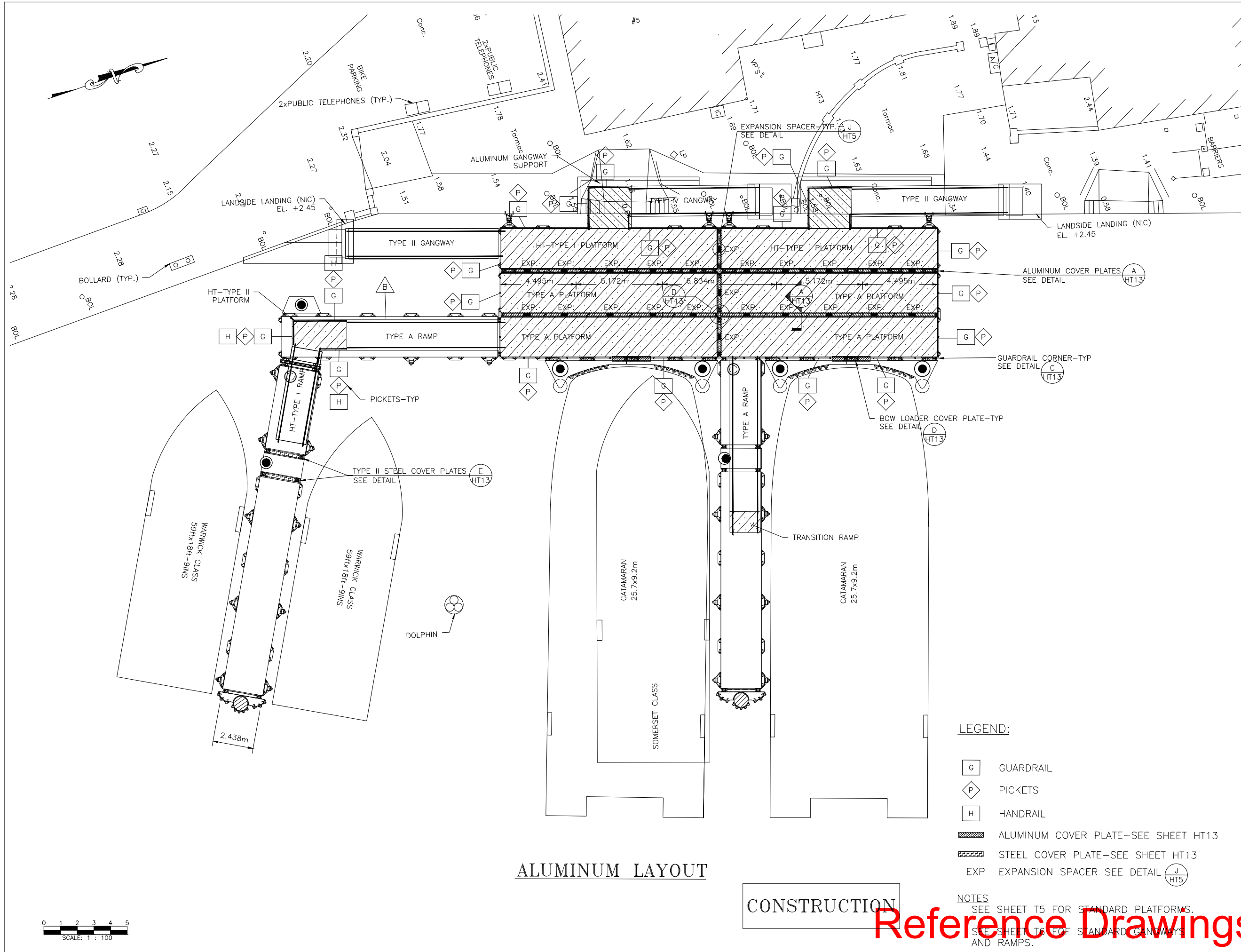

LEGEND:

- G GUARDRAIL
- P PICKETS
- H HANDRAIL
- ALUMINUM COVER PLATE-SEE SHEET HT13
- STEEL COVER PLATE-SEE SHEET HT13
- EXP EXPANSION SPACER SEE DETAIL

NOTES  
SEE SHEET T5 FOR STANDARD PLATFORMS.  
SEE SHEET T6 FOR STANDARD GANGWAYS  
AND RAMP.

CONSTRUCTION

Reference Drawings

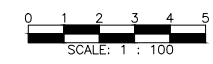

Structures Section

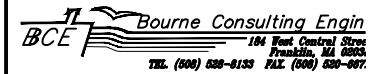

GENERAL NOTES:

ISSUED FOR: CONSTRUCTION 14/08/01

AMENDMENTS:

NO:	REVISION	APP	DATE:
Δ	REVISED AS NOTED	RRB	04/01/02

SCALE: AS NOTED

SURVEY

PREPARED BY: DATE:

DESIGN

PREPARED BY: BAP DATE: 23/05/01

CHECKED BY: RRB DATE: 23/05/01

DRAWING

PREPARED BY: JSK DATE: 23/05/01

CHECKED BY: BAP DATE: 23/05/01

APPROVED BY: RRB

PROJECT NUMBER:

61/01/01

PROJECT NAME:

HAMILTON TERMINAL  
REPLACEMENT FERRY PROJEC  
PHASE 1  
DOCK CONSTRUCTION

#1 POINT PLEASANT ROAD  
PEMBROKE PARISH

DRAWING FILE NO: ACAD R-14  
HT-5 Assembly-Connections.dwg

SHEET TITLE:

ASSEMBLY  
CONNECTION DETAILS

SHEET NUMBER: 13/26/02/HT5

REVISION

Δ

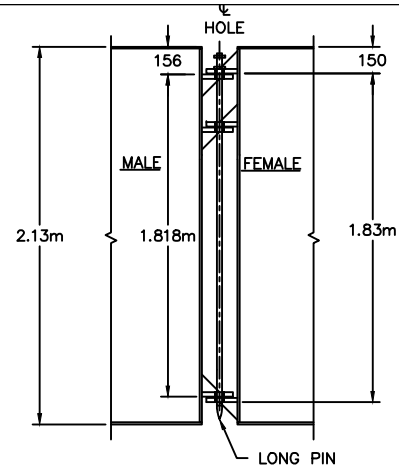

A HT5 HIGH BARGE CONNECTION

SCALE: 1 : 20

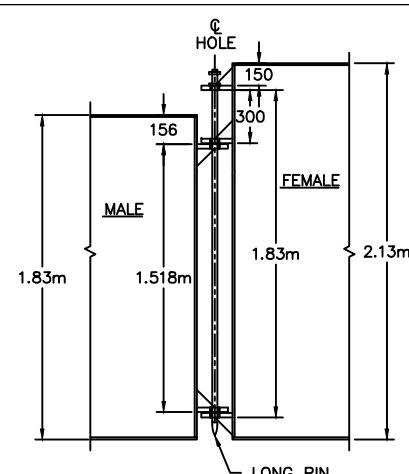

B HT5 HIGH/LOW BARGE CONNECTION

SCALE: 1 : 20

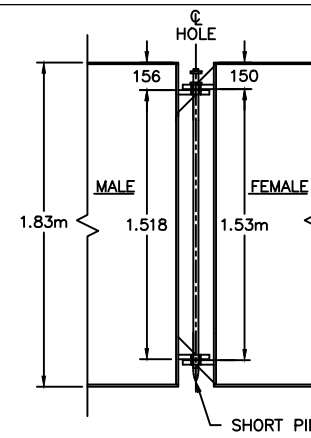

C HT5 LOW BARGE CONNECTION  
PILE GUIDE CONN. SIMILAR

SCALE: 1 : 20

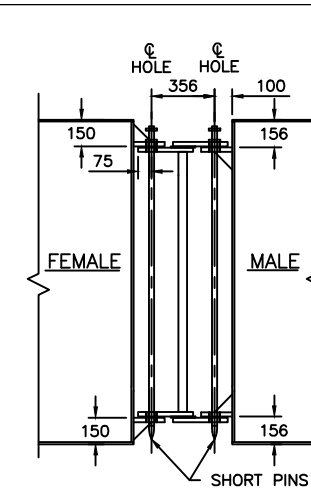

D HT5 BARGE CONNECTION - DETAIL

SCALE: 1 : 20

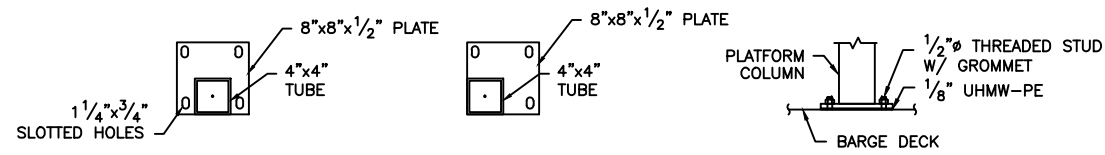

NOTE:  
CONNECTION SHALL BE 4-1/2" SS THD' STUDS W/GROMMET,  
NUT & WASHER WITH 1/8"x9"x9" UHMW-PE BELOW BASE PLATE

E HT5 PLATFORM BASE CONNECTION

SCALE: 1 : 10

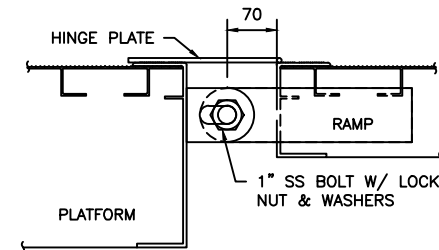

F HT5 RAMP TO PLATFORM CONNECTION

SCALE: 1 : 5

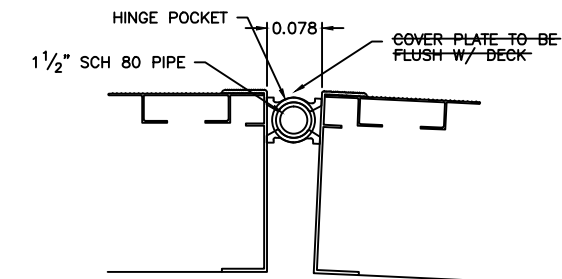

NOTE  
SECURE SCH 80 PIPE TO PREVENT LONGITUDINAL MOVEMENT

G HT5 STANDARD HINGE POCKET CONNECTION

SCALE: 1 : 5

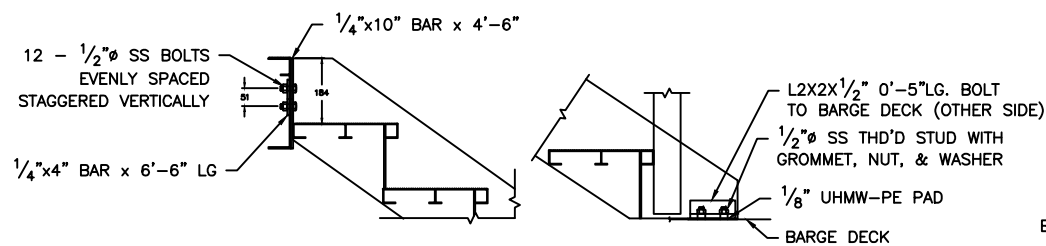

H HT5 STAIR CONNECTIONS

SCALE: 1 : 10

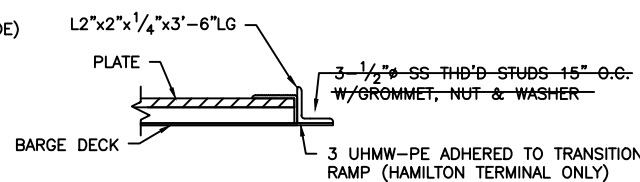

I HT5 TRANSITION CONNECTION

SCALE: 1 : 5

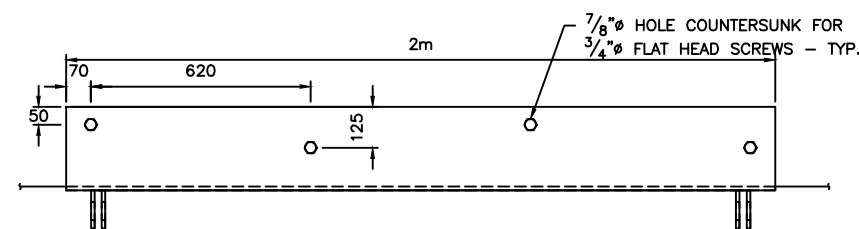

K HT5 PLAN

K HT5 GANGWAY LANDSIDE CONNECTION - STANDARD DETAIL

SCALE: 1 : 10

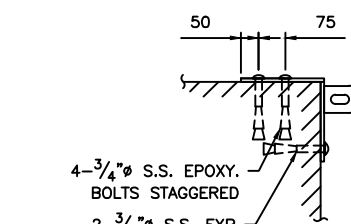

L HT5 SECTION

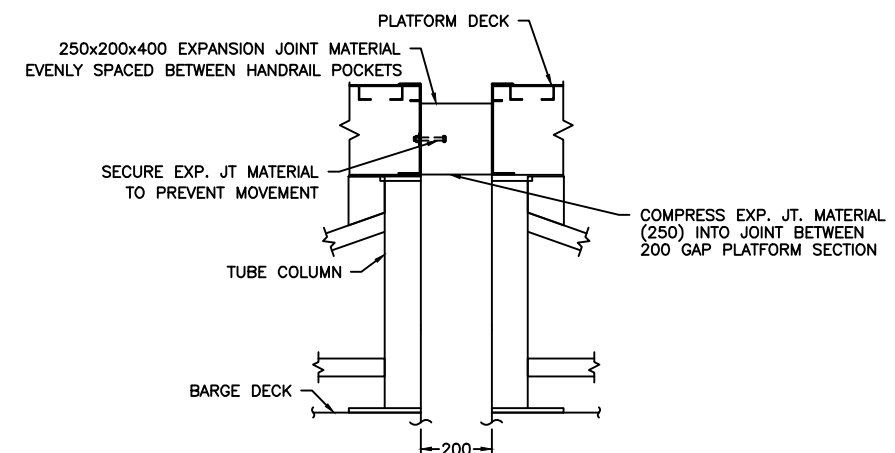

J HT5 PLATFORM TO PLATFORM CONNECTION

SCALE: 1 : 10

Reference Drawings CONSTRUCTION

Structures Section

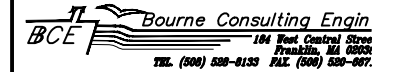

GENERAL NOTES:

ISSUED FOR: CONSTRUCTION 14/08/01

AMENDMENTS:

NO:	REVISION	APP	DATE:
B	HOOP ORIENTATION	RRB	04/01/02
C	BALLAST LAYOUT	RRB	11/01/02

SCALE: 1 : 100

SURVEY  
PREPARED BY: DATE: 23/05/01

DESIGN  
PREPARED BY: BAP DATE: 23/05/01  
CHECKED BY: RRB DATE: 23/05/01

DRAWING  
PREPARED BY: JSK DATE: 23/05/01  
CHECKED BY: BAP DATE: 23/05/01

APPROVED BY: RRB

PROJECT NUMBER: 61/01/01

PROJECT NAME:  
**HAMILTON TERMINAL  
REPLACEMENT FERRY PROJEC  
PHASE 1  
DOCK CONSTRUCTION**

**#1 POINT PLEASANT ROAD  
PEMBROKE PARISH**

DRAWING FILE NO: ACAD R-14  
HT-6\_Ballasting\_Plan

SHEET TITLE:  
**BALLASTING  
PLAN**

SHEET NUMBER: 13/26/02/HT6

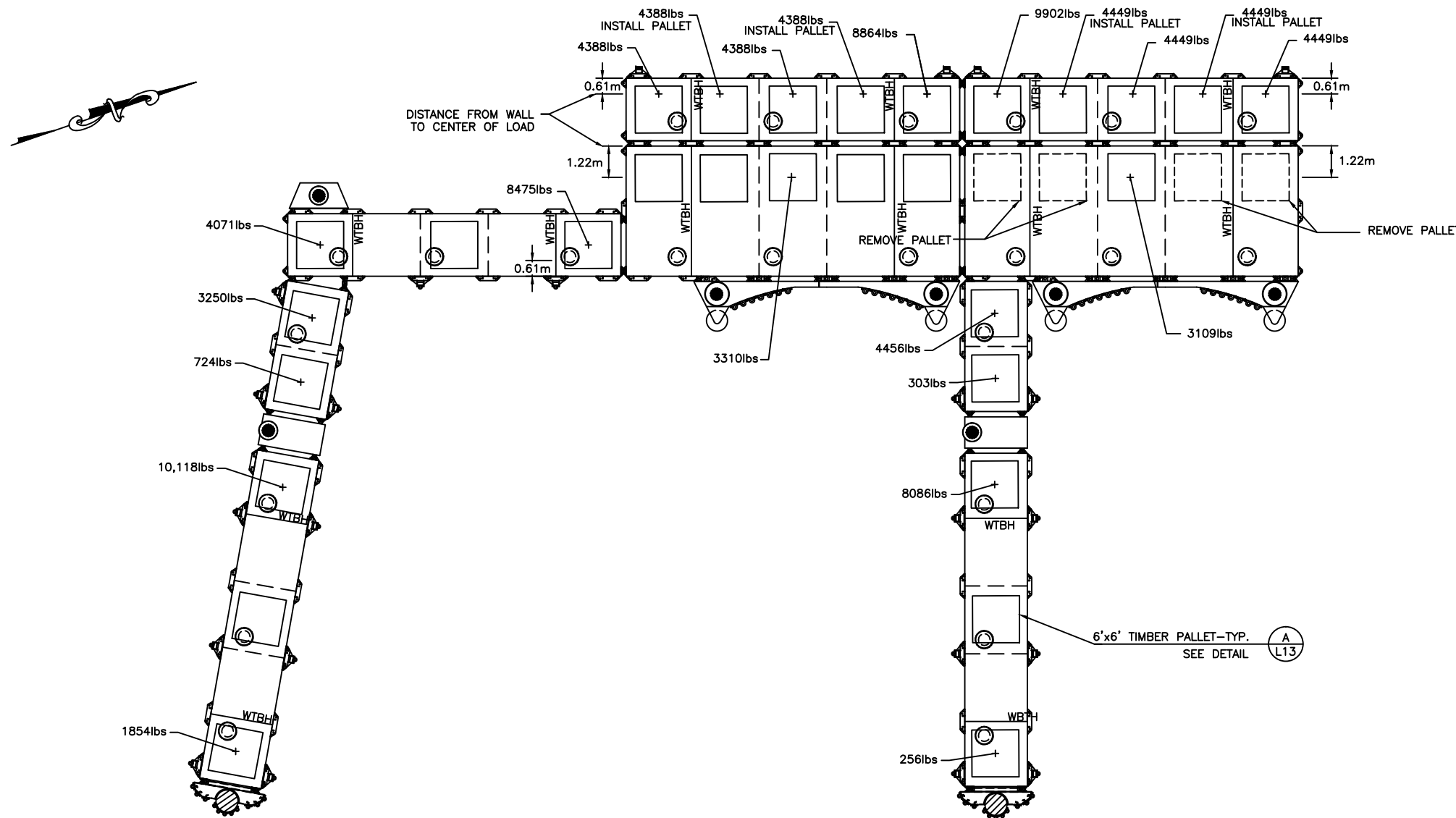

HAMILTON TERMINAL

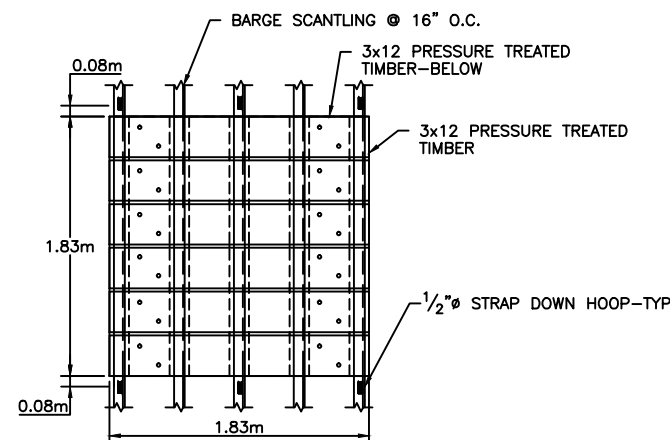

**BALLAST PALLET-PLAN**

SCALE: 1 : 25

**CONSTRUCTION**

NOTES:

- BALLAST LOADS ARE SHOWN AT CENTER OF BAY UNLESS NOTED OTHERWISE.
- BALLAST TO BE REMOVABLE CONCRETE BLOCK OR LEAD.
- BALLAST SHALL BE INSTALLED ON TIMBER PALLETS AT LOCATIONS SHOWN. PALLETS SUPPLIED WITH BARGES.

Reference Drawings

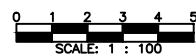

SCALE: 1 : 100

Structures Section

*BCE* Bourne Consulting Engin  
184 West Central Street  
Franklin, MA 02045  
TEL (508) 538-0133 FAX (508) 538-0077

GENERAL NOTES:

ISSUED FOR: CONSTRUCTION 14/08/01

AMENDMENTS:

NO:	REVISION	APP	DATE:

SCALE: 1 : 50

SURVEY

PREPARED BY: DATE:

DESIGN

PREPARED BY: BAP DATE: 23/05/01

CHECKED BY: RRB DATE: 23/05/01

DRAWING

PREPARED BY: JSK DATE: 23/05/01

CHECKED BY: BAP DATE: 23/05/01

APPROVED BY: RRB

PROJECT NUMBER: 61/01/01

PROJECT NAME:

HAMILTON TERMINAL  
REPLACEMENT FERRY PROJEC

PHASE 1  
DOCK CONSTRUCTION

#1 POINT PLEASANT ROAD  
PEMBROKE PARISH

DRAWING FILE NO: ACAD R-14  
HT-8 Wall Notch.dwg

SHEET TITLE:

WALL NOTCH  
CONSTRUCTION

SHEET NUMBER: 13/26/02/HT8

REVISION

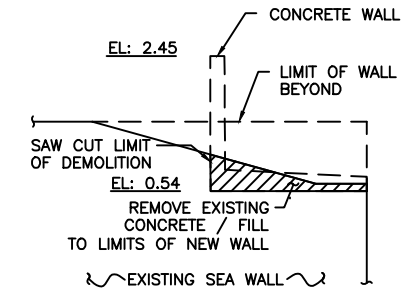
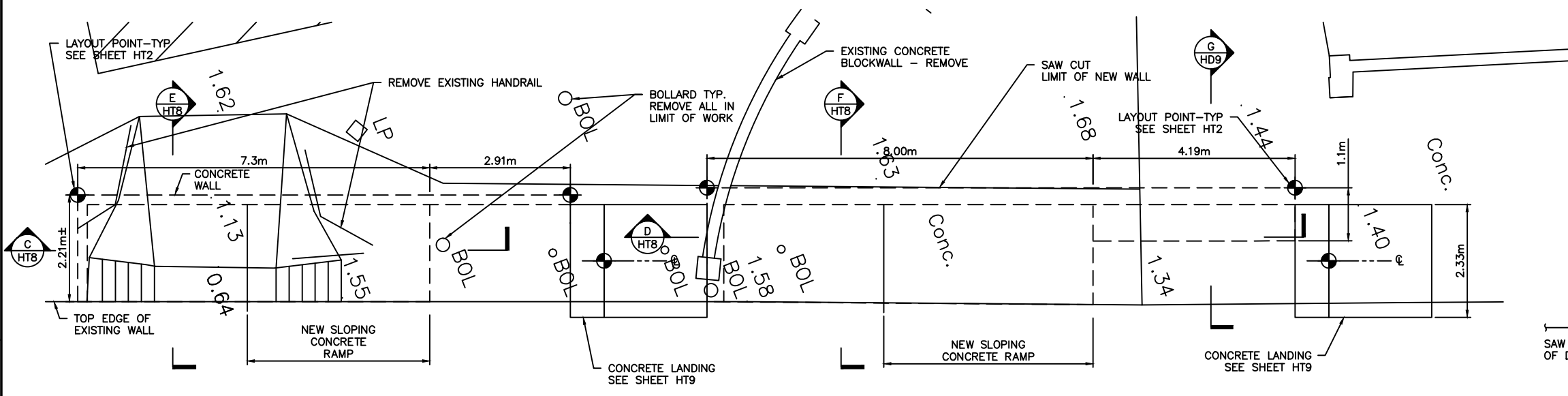

**SOUTH NOTCH SECTION**  
SCALE: 1 : 50

**SOUTH NOTCH - PLAN**  
SCALE: 1 : 50

**NORTH NOTCH - PLAN**  
SCALE: 1 : 50

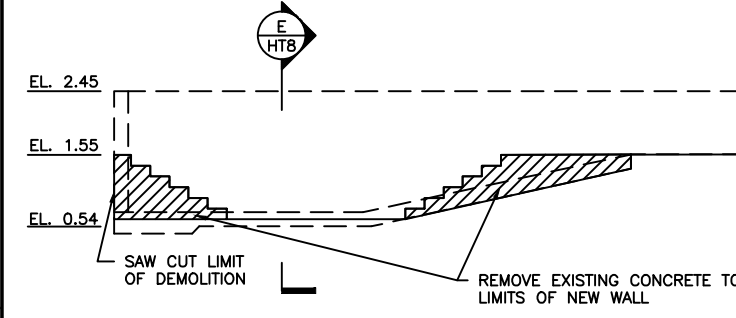

**SOUTH NOTCH - ELEVATION**  
SCALE: 1 : 50

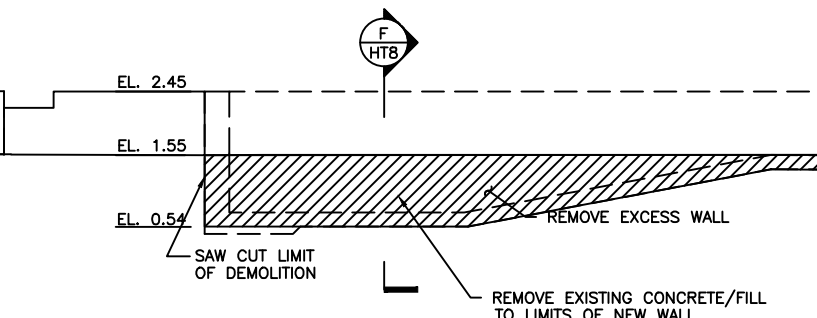

**NORTH NOTCH - ELEVATION**  
SCALE: 1 : 50

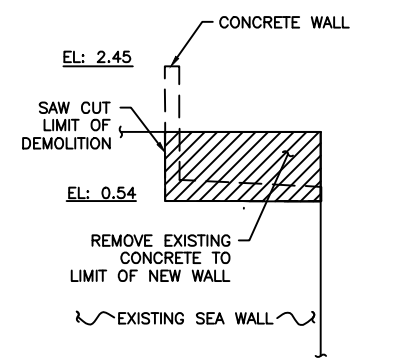

**NORTH NOTCH SECTION**  
SCALE: 1 : 50

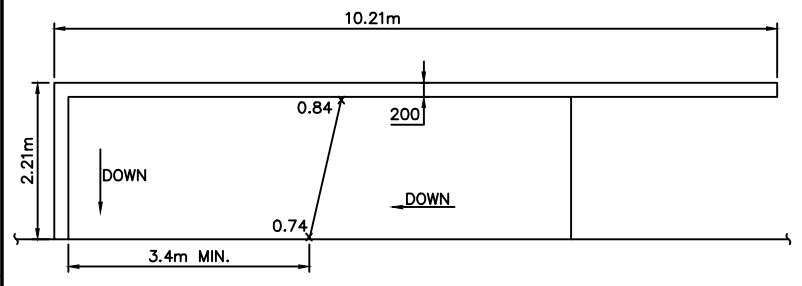

**SOUTH NOTCH - PLAN**  
SCALE: 1 : 50

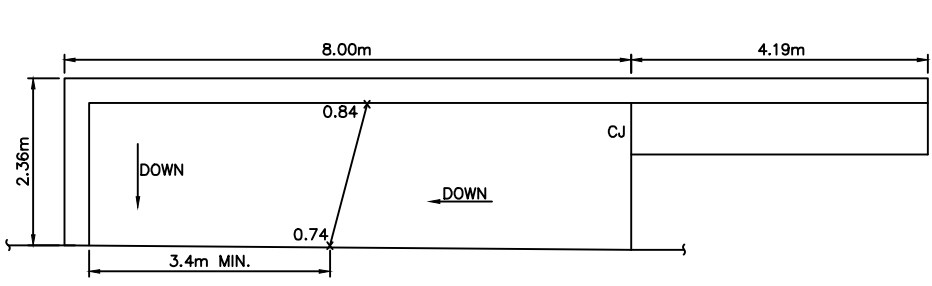

**NORTH NOTCH - PLAN**  
SCALE: 1 : 50

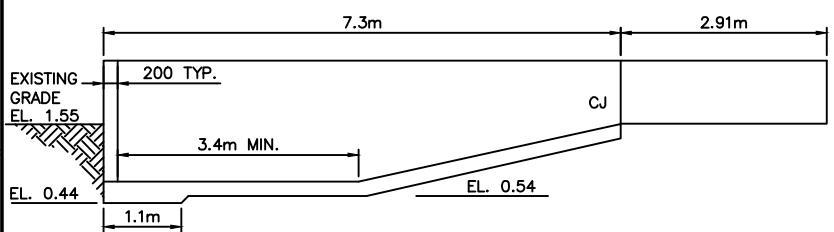

**SOUTH NOTCH - ELEVATION**  
SCALE: 1 : 50

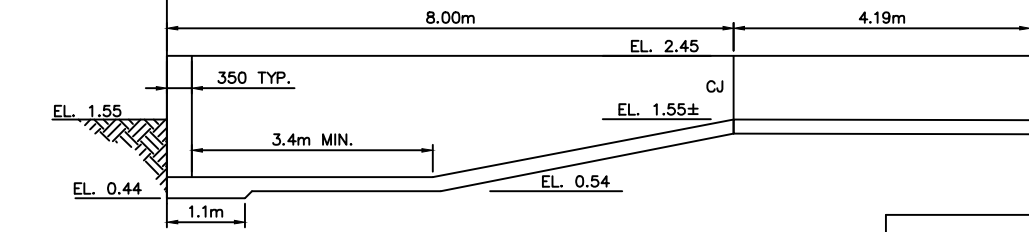

**NORTH NOTCH - ELEVATION**  
SCALE: 1 : 50

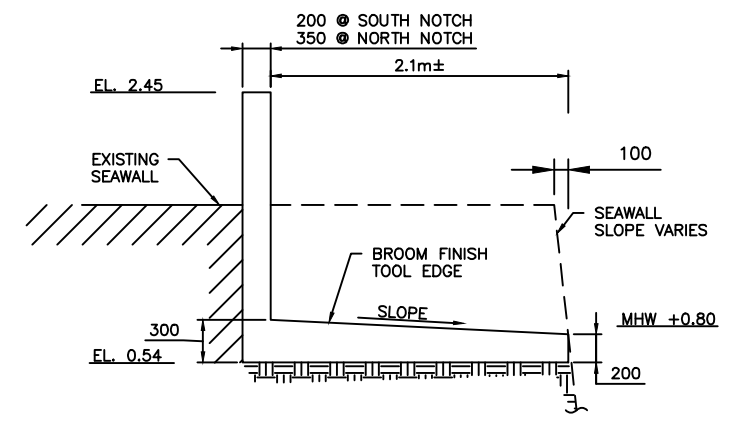

**WALL - CROSS SECTION**  
SCALE: 1 : 25

CONSTRUCTION

NOTE:  
\* ALL REINFORCING STEEL TO BE HOT DIPPED GALVANIZED.  
\* REINFORCING SHALL HAVE A MINIMUM COVER OF 75mm.  
\* 25 CHAMFER ON ALL EDGES UNO.

Reference Drawings

SHEET NUMBER: 13/26/02/HT8

REVISION

Structures Section

GENERAL NOTES:

ISSUED FOR: CONSTRUCTION 14/08/01

AMENDMENTS:

NO:	REVISION	APP	DATE:

SCALE: AS NOTED

SURVEY

PREPARED BY: DATE:

DESIGN

PREPARED BY: BAP DATE: 23/05/01

CHECKED BY: RRB DATE: 23/05/01

DESIGN

PREPARED BY: RFG DATE: 23/05/01

CHECKED BY: RRB DATE: 23/05/01

APPROVED BY: RRB

PROJECT NUMBER: 61/01/01

PROJECT NAME:

HAMILTON TERMINAL

REPLACEMENT FERRY PROJEC

PHASE 1

DOCK CONSTRUCTION

#1 POINT PLEASANT ROAD

PEMBROKE PARISH

DRAWING FILE NO: ACAD R-14

HT-10\_Gandway\_Pier\_Ext.dwg

SHEET TITLE:

GANGWAY PIER

EXTENTION

SHEET NUMBER: 13/26/02/HT10

REVISION

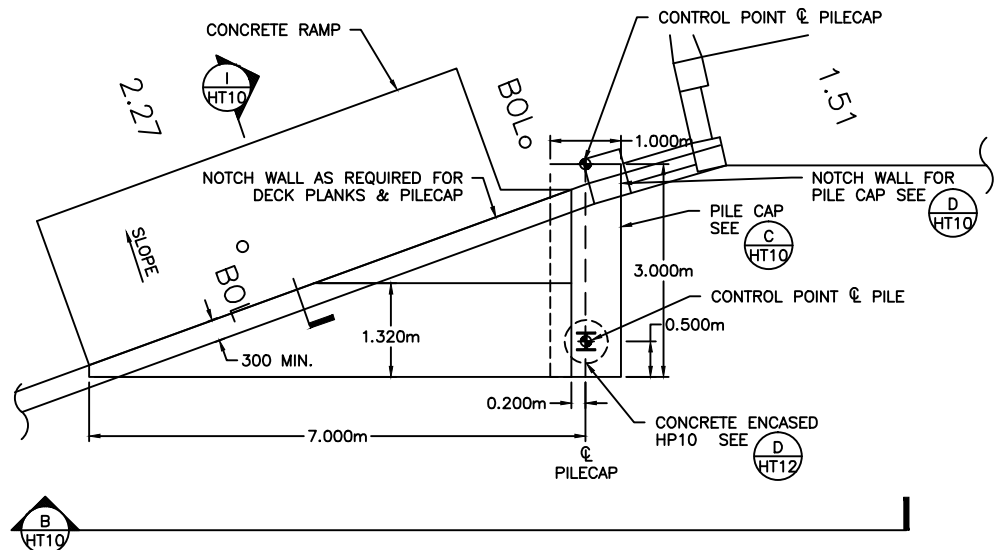

GANGWAY PIER  
EXTENTION-PLAN

(A)  
HT10

SCALE: 1 : 50

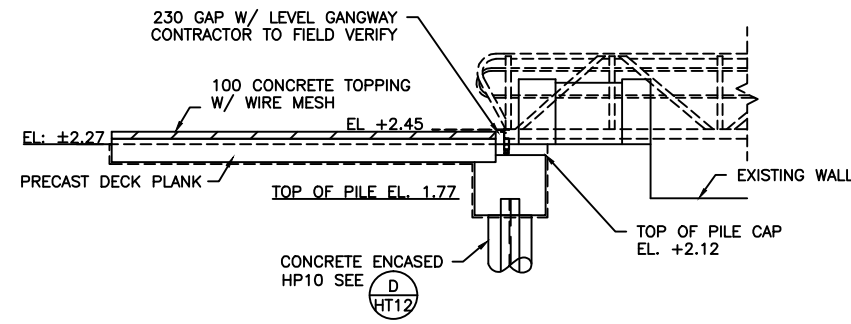

GANGWAY PIER  
EXTENTION-ELEVATION

(B)  
HT10

SCALE: 1 : 50

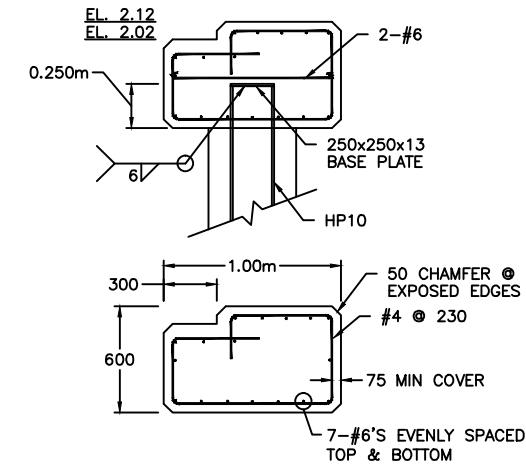

PILE CAP-REINFORCING

(C)  
HT10

SCALE: 1 : 20

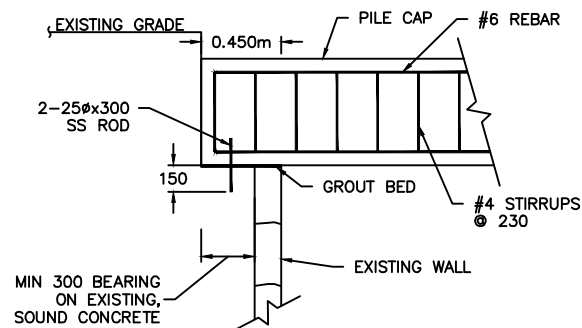

PILE CAP NOTCH

(D)  
HT10

SCALE: 1 : 20

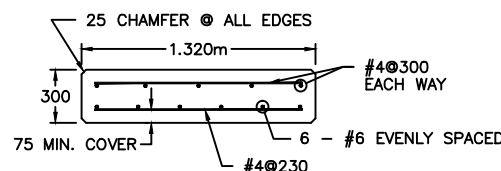

PIER SLAB-REINFORCING

(E)  
HT10

SCALE: 1 : 20

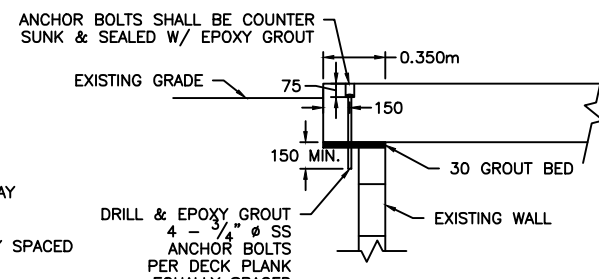

SLAB / WALL CONNECTION

(F)  
HT10

SCALE: 1 : 20

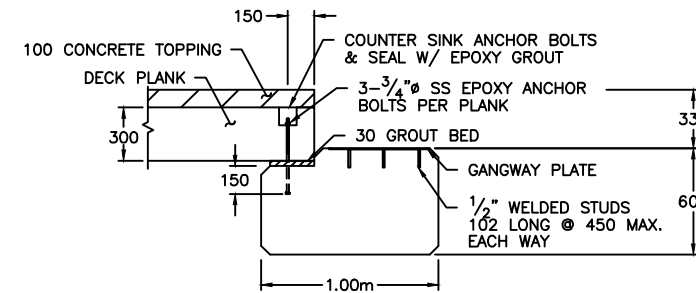

PILE CAP-DETAIL

(G)  
HT10

SCALE: 1 : 20

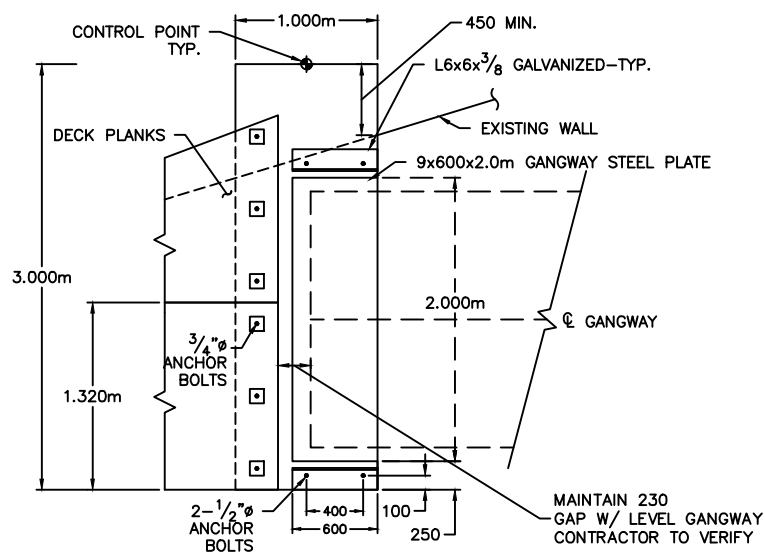

PILE CAP PLAN

(H)  
HT10

SCALE: 1 : 25

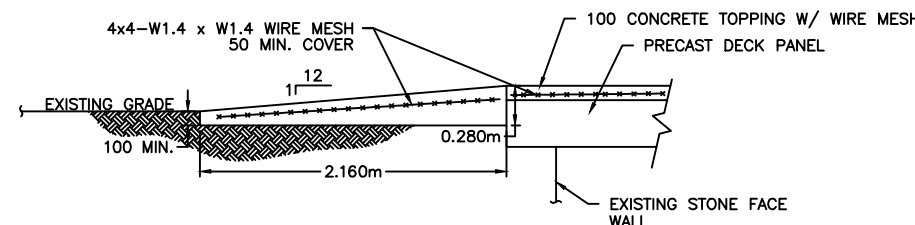

TRANSITION RAMP

(I)  
HT10

SCALE: 1 : 25

Reference CONSTRUCTION Drawings

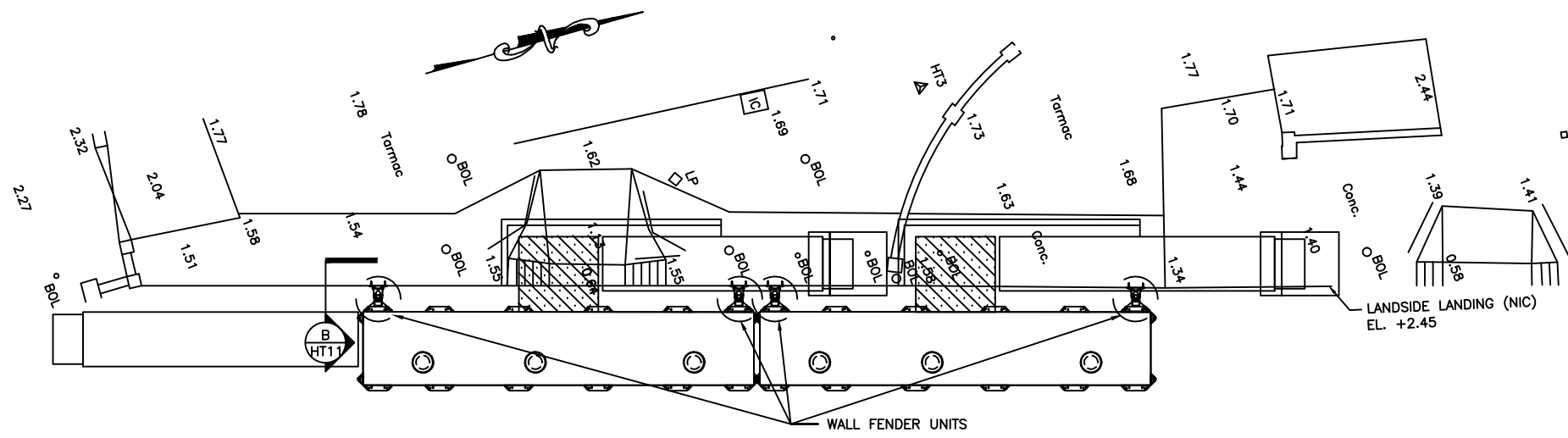

**TERMINAL PARTIAL PLAN**  
 SCALE: 1 : 50

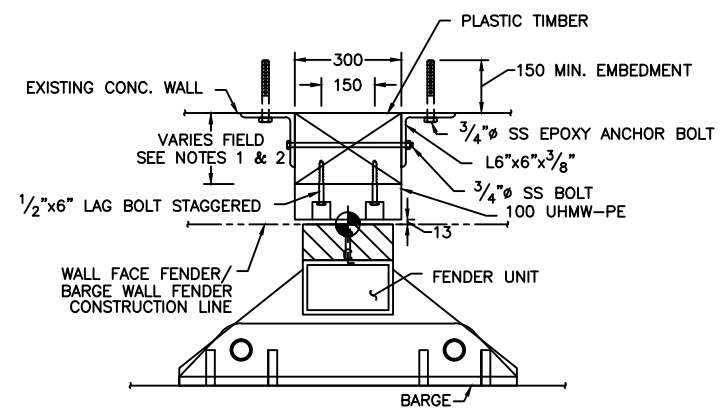

**WALL FENDER PLAN**  
 SCALE: 1 : 10

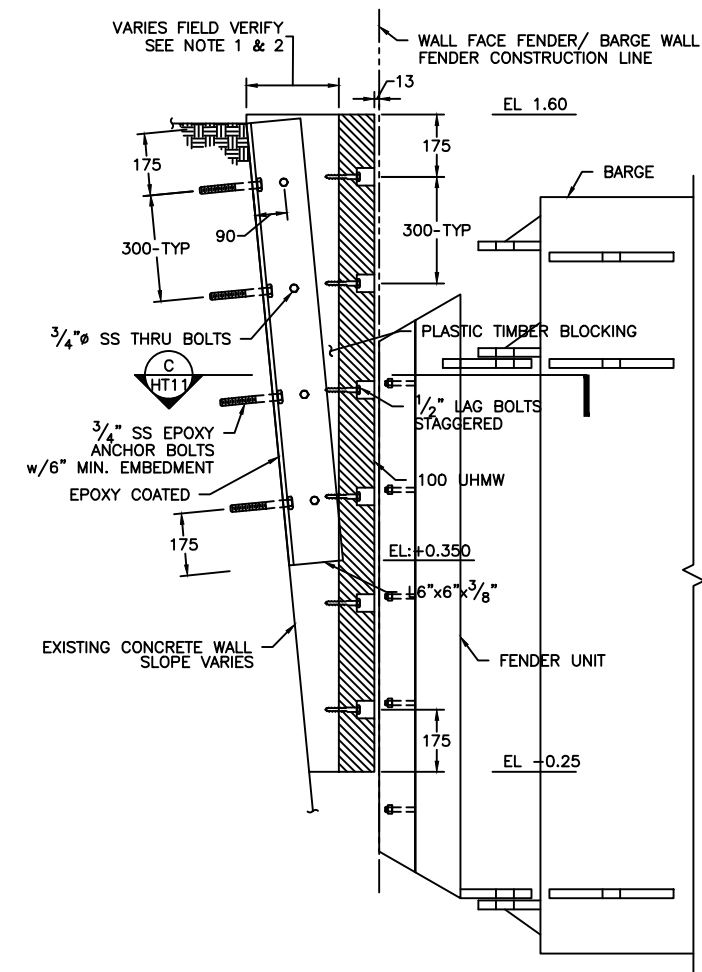

**WALL FENDER DETAIL**  
 SCALE: 1 : 10

- NOTES
1. PLASTIC TIMBER SHALL HAVE MINIMUM THICKNESS OF 100mm @ EL:+0.35.
  2. CONTRACTOR TO FIELD VERIFY SEAWALL SLOPE AND FINAL WALL FACE FENDER/ BARGE WALL FENDER CONSTRUCTION LINE.

**THE MINISTRY OF WORKS AND ENGINEERING**

P.O. Box HM525 Hamilton HM CX Bermuda  
 Phone: (441)295-5151

ENGINEERING and OPERATIONS DIVISION  
 Fax: (441)295-0170

**Structures Section**

*Bourne Consulting Engin*  
 BCE 184 West Central Street  
 Providence, RI 02903  
 TEL. (508) 828-8133 FAX. (508) 828-8977

GENERAL NOTES:

ISSUED FOR: CONSTRUCTION 14/08/01

AMENDMENTS:

NO:	REVISION	APP	DATE:

SCALE: AS NOTED

SURVEY  
 PREPARED BY: DATE:

DESIGN  
 PREPARED BY: BAP DATE: 23/05/01  
 CHECKED BY: RRB DATE: 23/05/01

DRAWING  
 PREPARED BY: JSK DATE: 23/05/01  
 CHECKED BY: BAP DATE: 23/05/01

APPROVED BY: RRB

PROJECT NUMBER:  
 61/01/01

PROJECT NAME:  
**HAMILTON TERMINAL  
 REPLACEMENT FERRY PROJECT  
 PHASE 1  
 DOCK CONSTRUCTION**

**#1 POINT PLEASANT ROAD  
 PEMBROKE PARISH**  
 DRAWING FILE NO: ACAD R-14  
 HT-11\_Wall-Fender.dwg

SHEET TITLE:  
**WALL  
 FENDER**

SHEET NUMBER:  
 13/26/02/HT11

REVISION  
 ^

Reference Drawings CONSTRUCTION

GENERAL NOTES:

ISSUED FOR: CONSTRUCTION 14/08/01

AMENDMENTS:

NO:	REVISION	APP	DATE:
Δ	WEAR SURFACE	RRB	04/01/02

SCALE: AS NOTED

SURVEY

PREPARED BY: DATE:

DESIGN

PREPARED BY: BAP DATE: 23/05/01

CHECKED BY: RRB DATE: 23/05/01

DRAWING

PREPARED BY: BAP DATE: 23/05/01

CHECKED BY: RRB DATE: 23/05/01

APPROVED BY: RRB

PROJECT NUMBER: 61/01/01

PROJECT NAME:

HAMILTON TERMINAL  
REPLACEMENT FERRY PROJECT  
PHASE 1  
DOCK CONSTRUCTION

#1 POINT PLEASANT ROAD  
PEMBROKE PARISH

DRAWING FILE NO: ACAD R-14

HT-12 Mooring Piles.dwg

SHEET TITLE:

MOORING PILES

SHEET NUMBER: 13/26/02/HT12

REVISION

Δ

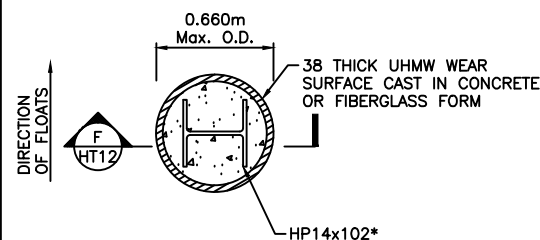

\* NOTE: PILE SHALL BE ORIENTED PERPENDICULAR TO FLOATS

A TYPE I MOORING PILE

SCALE: 1 : 20

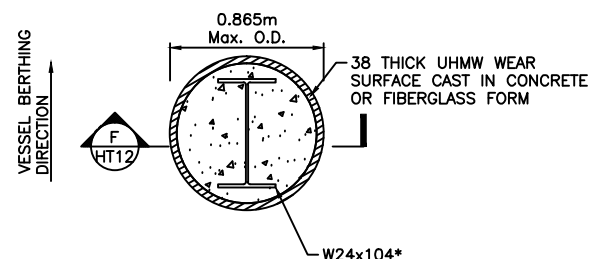

\* NOTE: PILE SHALL BE ORIENTED IN VESSEL BERTHING DIRECTION

B TYPE II MOORING PILE

SCALE: 1 : 20

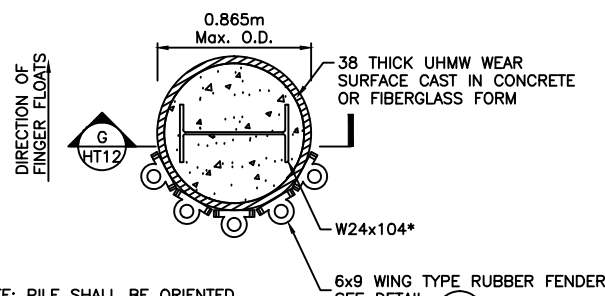

\* NOTE: PILE SHALL BE ORIENTED PERPENDICULAR TO FINGER FLOATS

C TYPE III MOORING PILE

SCALE: 1 : 20

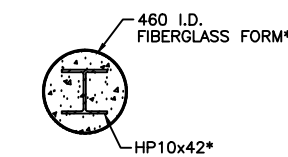

\* ONE OR TWO PIECE REMOVABLE FORMS ALLOWED

D STANDARD BEARING PILE

SCALE: 1 : 20

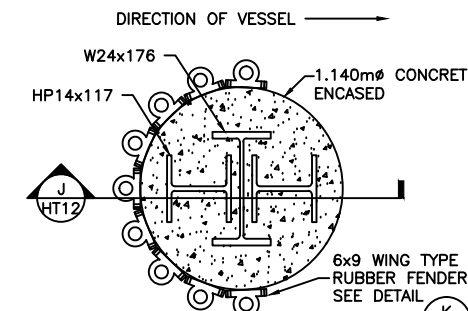

E SIDE DOLPHIN PLAN @ ELEV. 0.0M

SCALE: 1 : 20

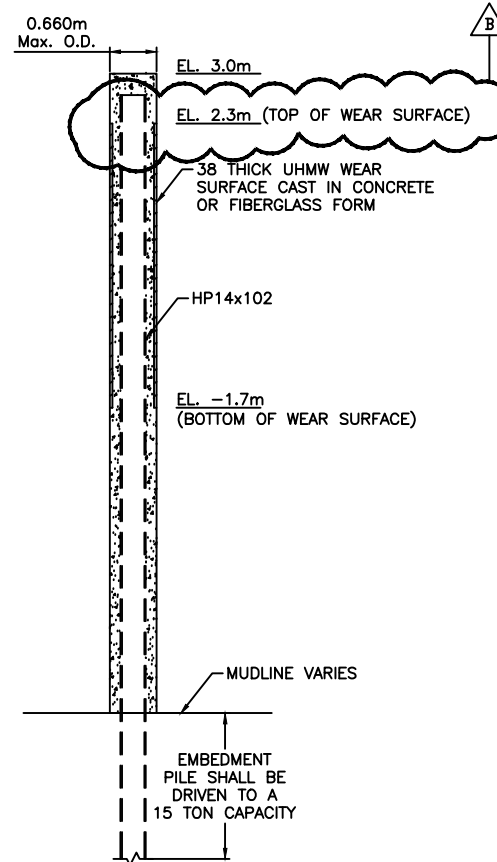

F TYPE I MOORING PILE - SECTION

SCALE: 1 : 50

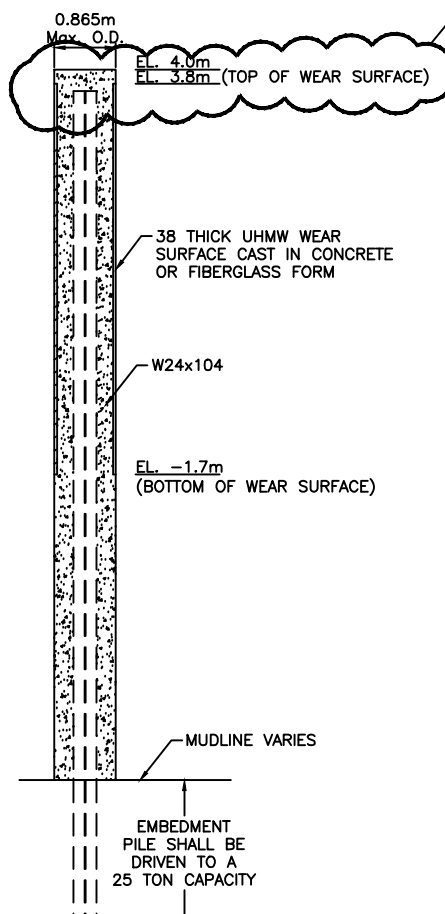

G TYPE II MOORING PILE - SECTION

SCALE: 1 : 50

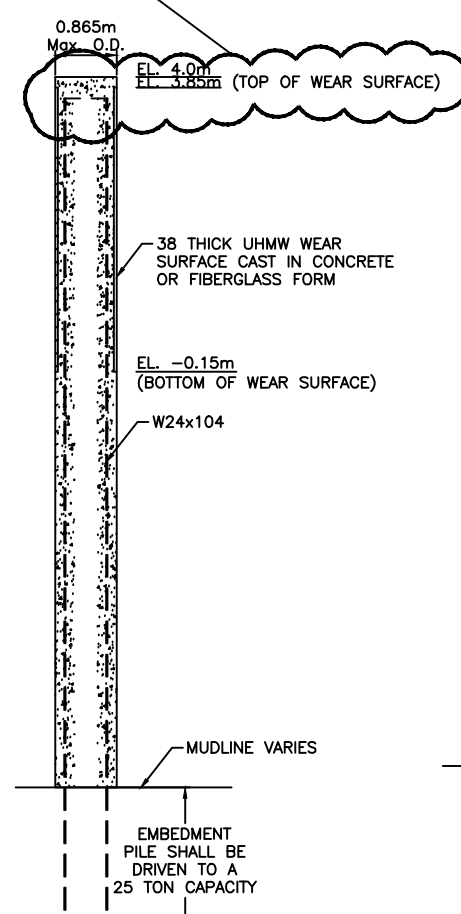

H TYPE III MOORING PILE - SECTION

SCALE: 1 : 50

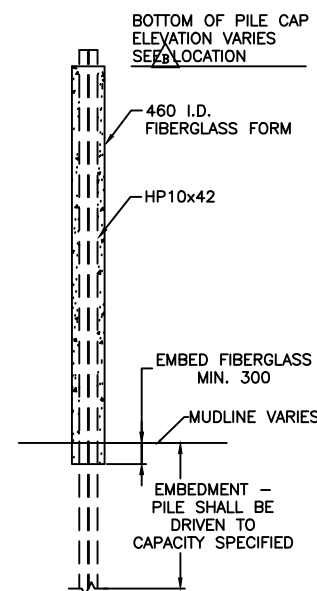

I STANDARD BEARING PILE - SECTION

SCALE: 1 : 50

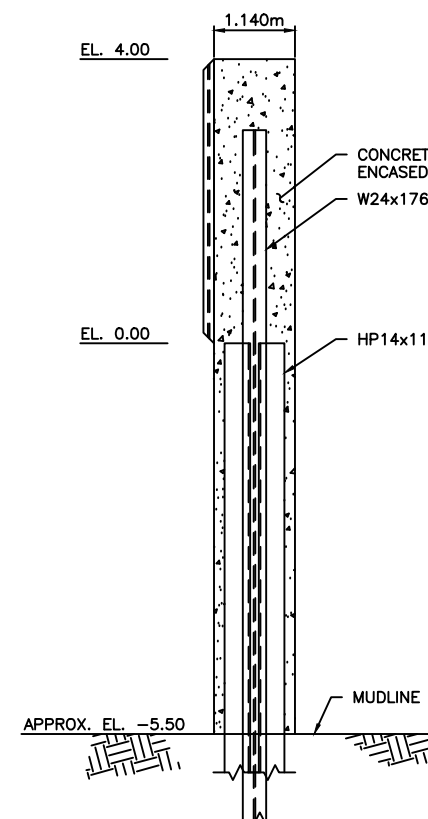

J SIDE DOLPHIN - SECTION

SCALE: 1 : 50

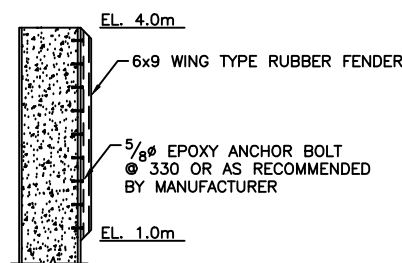

K RUBBER UNIT - CONNECTION

SCALE: 1 : 50

NOTE: FIBERGLASS FORMS MAYBE 1 OR 2 PIECE REMOVABLE FORMS

PILE TYPE	ASSUMED TIP ELEV. FOR TENDER
MOORING PILE TYPE I	-37.5
MOORING PILE TYPE II	-37.5
MOORING PILE TYPE III	-37.5
STD. BEARING PILE	-37.5
DOLPHIN	-37.5

CONSTRUCTION

Reference Drawings

GENERAL NOTES:

ISSUED FOR: CONSTRUCTION 14/08/01

AMENDMENTS:

NO:	REVISION	APP	DATE:
△	TYPE I PLATE	RRB	04/01/02

SCALE: AS NOTED

SURVEY  
PREPARED BY: DATE:

DESIGN  
PREPARED BY: BAP DATE: 23/05/01  
CHECKED BY: RRB DATE: 23/05/01

DRAWING  
PREPARED BY: JSK DATE: 23/05/01  
CHECKED BY: BAP DATE: 23/05/01

APPROVED BY: RRB

PROJECT NUMBER:  
61/01/01

PROJECT NAME:  
**HAMILTON TERMINAL  
REPLACEMENT FERRY PROJEC  
PHASE 1  
DOCK CONSTRUCTION**

**#1 POINT PLEASANT ROAD  
PEMBROKE PARISH**

DRAWING FILE NO: ACAD R-14  
HT-13 Misc. Details.dwg

SHEET TITLE:  
**MISC.  
DETAILS**

SHEET NUMBER: 13/26/02/HT13 REVISION: △

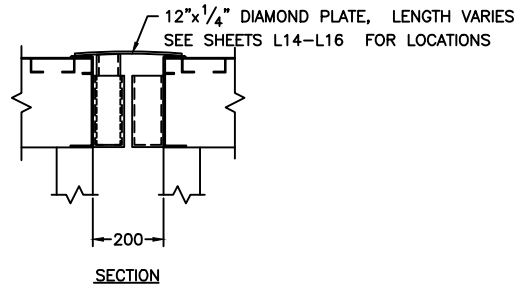

**PLATFORM TO PLATFORM TRANSITION PLATE**

SCALE: 1 : 10

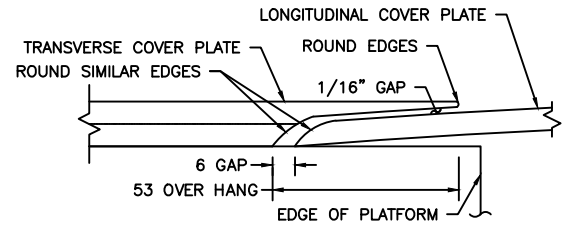

**COVER PLATE CROSSING-SECTION**

SCALE: 1 : 1

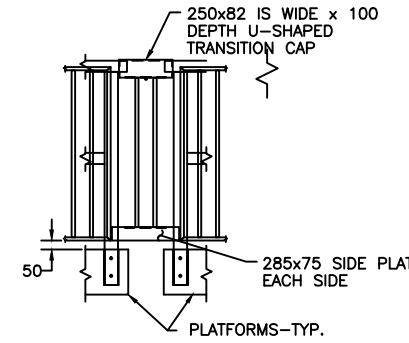

**HANDRAIL CONNECTION**

SCALE: 1 : 20

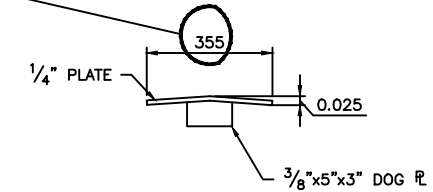

**SECTION**

SCALE: 1 : 10

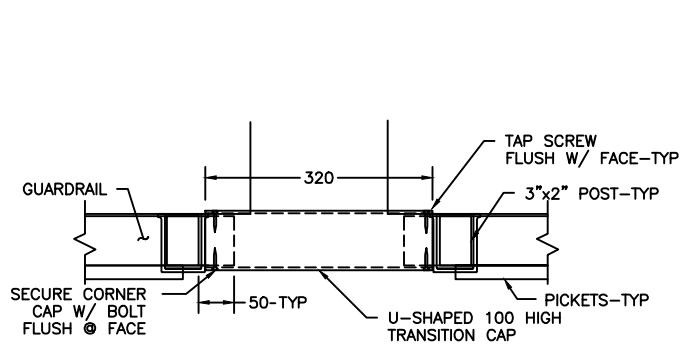

**GUARDRAIL TRANSITION**

SCALE: 1 : 5

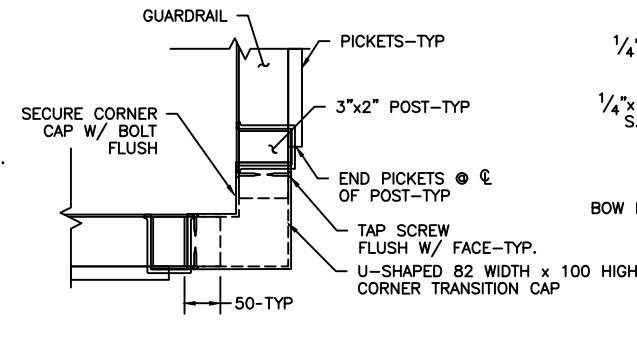

**BOW LOADER COVER PLATE**

SCALE: 1 : 10

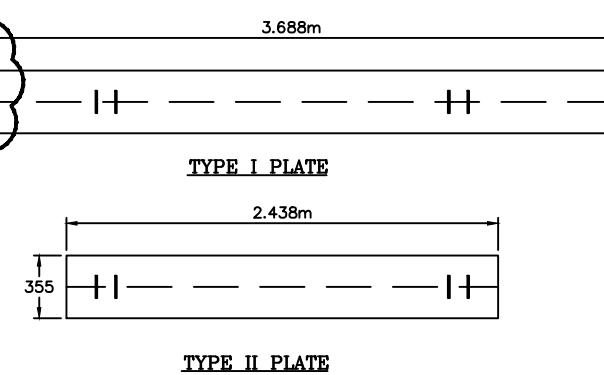

**STEEL BARGE COVER PLATES**

SCALE: 1 : 20



Structures Section



GENERAL NOTES:

1. COORDINATES BASED ON BNG 2000.
2. ALL ELEVATIONS ARE IN METERS BASED ON ORDNANCE DATUM.
3. ALL DISTANCES ARE IN METERS.
4. SURVEY CONTROL SHALL BE PROVIDED TO THE CONTRACTOR BY THE OWNER.

ISSUED FOR: CONSTRUCTION 14/08/01

AMENDMENTS:

NO:	REVISION	APP	DATE:

SCALE: 1 : 200

SURVEY

PREPARED BY: DATE:

DESIGN

PREPARED BY: BAP DATE: 23/05/01

CHECKED BY: RRB DATE: 23/05/01

DRAWING

PREPARED BY: JSK DATE: 23/05/01

CHECKED BY: BAP DATE: 23/05/01

APPROVED BY:  
RRB

PROJECT NUMBER:  
61/01/01

PROJECT NAME:  
**DOCKYARD  
REPLACEMENT FERRY PROJECT  
PHASE 1  
DOCK CONSTRUCTION**

**DOCKYARD TERRACE  
SANDYS PARISH**

DRAWING FILE NO: ACAD R-14  
DY-01\_Exist Cond.dwg

SHEET TITLE:  
**EXISTING  
CONDITIONS**

SHEET NUMBER:  
61/45/01/DY1

REVISION  
▲

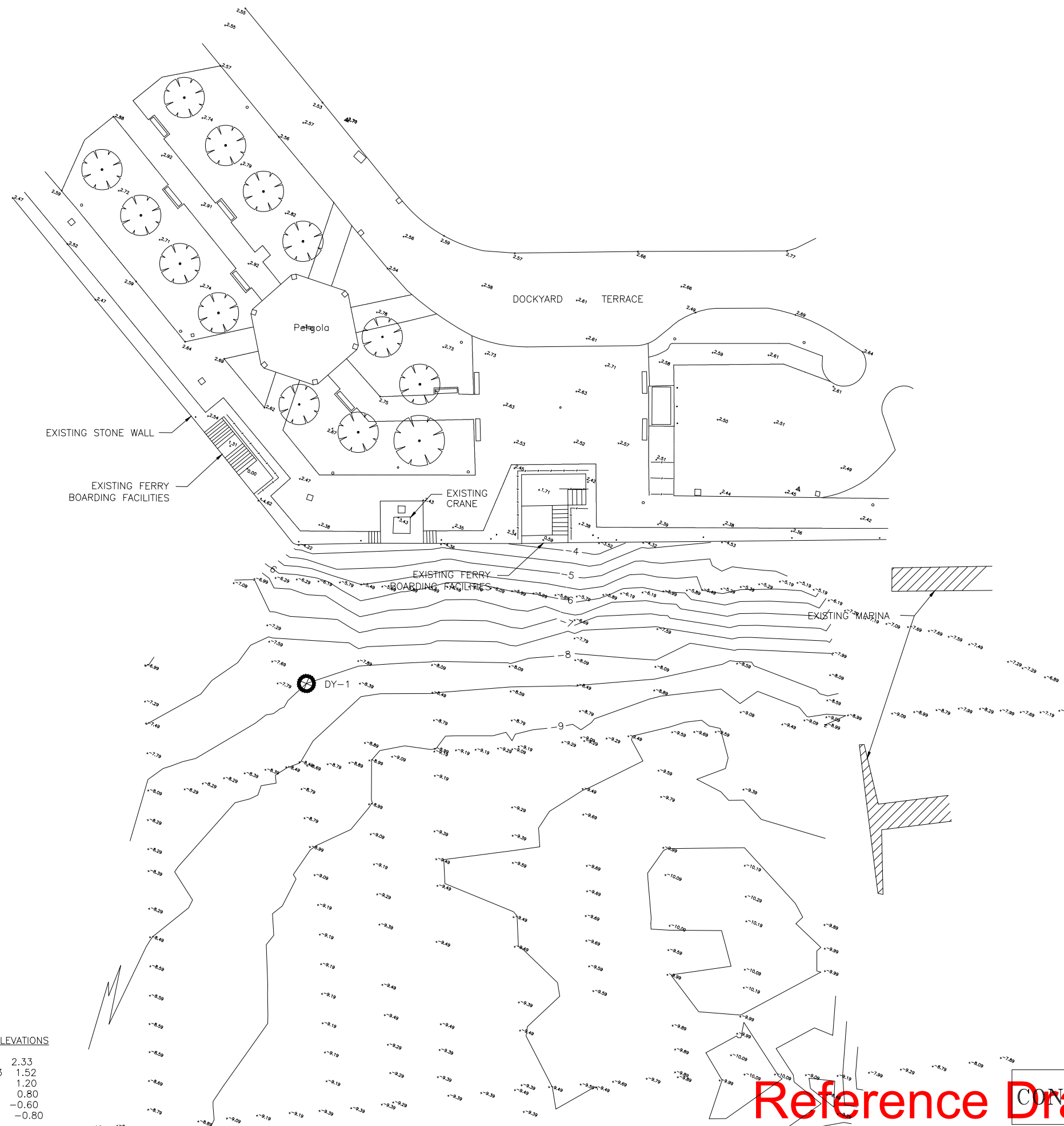

TEST PILE DRIVING LOGS	
DY-1	
DEPTH	HAMMER BLOWS/FT
MUDLINE EL: -8.2m	
0 FT	(BARGE HEIGHT) START
50	0
55	0
60	0
65	4
70	3
75	8
80	8
85	16
90	11
95	21
100	21
105	25
110	42 END
PILE: HP12x87	
HAMMER: DELMAG D8-22	
ENERGY: 18,000/9,500 FT-lbs/BLOW	

NOTES  
DY-1 TEST PILE LOCATION.  
ALL PILES EXTRACTED.  
PERFORMED DECEMBER 2000.

DESIGN WATER ELEVATIONS		
HURR.	CAT. 5	2.33
	CAT. 3	1.52
	EHW	1.20
	MHW	0.80
	MLW	-0.60
	ELW	-0.80

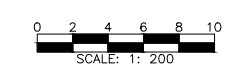

Reference Drawings

- GENERAL NOTES:
- COORDINATES BASED ON BNG 2000.
  - ALL ELEVATIONS ARE IN METERS BASED ON ORDNANCE DATUM.
  - ALL DISTANCES ARE IN METERS.
  - SURVEY CONTROL SHALL BE PROVIDED TO THE CONTRACTOR BY THE OWNER.

ISSUED FOR: CONSTRUCTION 14/08/01

AMENDMENTS:

NO:	REVISION	APP	DATE:
A	BARGES/ LAYOUTS	RRB	04/01/02

SCALE: 1 : 100

SURVEY  
PREPARED BY: DATE:

DESIGN  
PREPARED BY: DATE: 23/05/01  
BAP  
CHECKED BY: DATE: 23/05/01  
RRB

DRAWING  
PREPARED BY: DATE: 23/05/01  
JSK  
CHECKED BY: DATE: 23/05/01  
BAP

APPROVED BY:  
RRB

PROJECT NUMBER:  
61/01/01

PROJECT NAME:  
**DOCKYARD  
REPLACEMENT FERRY PROJECT  
PHASE 1  
DOCK CONSTRUCTION**

**DOCKYARD TERRACE  
SANDYS PARISH**

DRAWING FILE NO: ACAD R-14  
DY-3\_Barge\_Alum\_Assembly.dwg

SHEET TITLE:  
**BARGE & ALUMINUM  
ASSEMBLY PLAN**

SHEET NUMBER:  
61/45/01/DY3

REVISION  
A

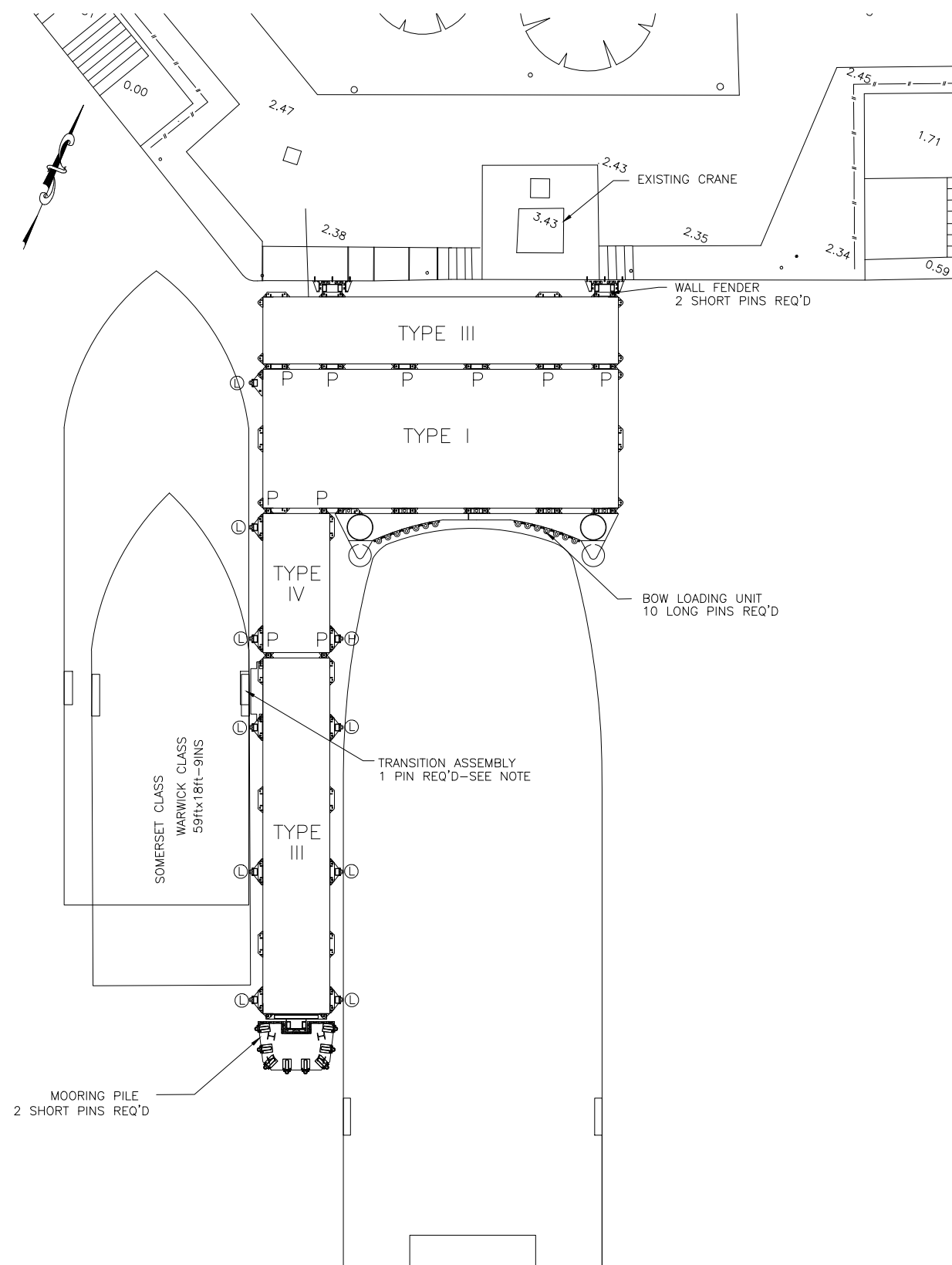

**BARGE LAYOUT**

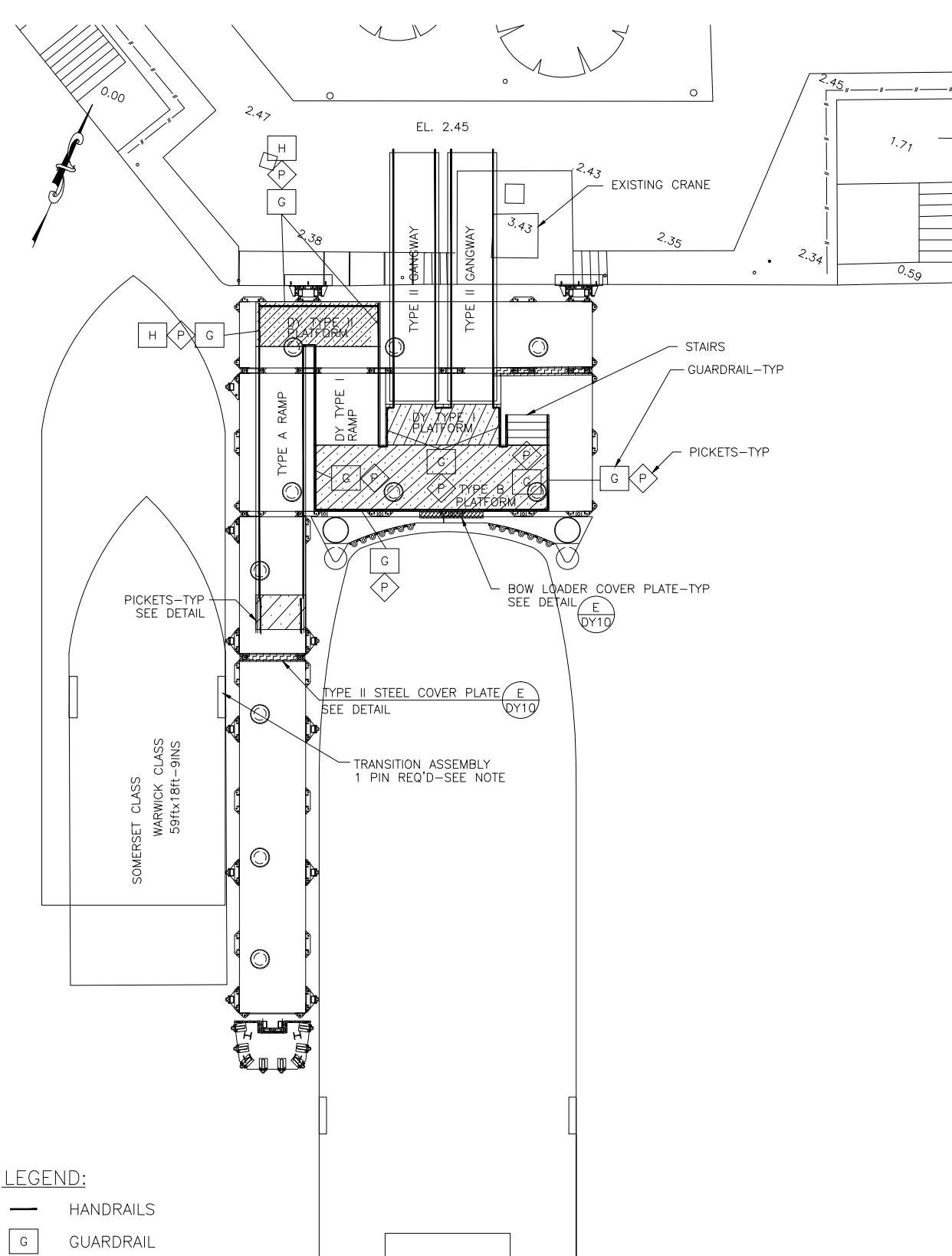

**ALUMINUM LAYOUT**

LEGEND:

- HANDRAILS
- G GUARDRAIL
- P PICKETS
- H HANDRAIL
- ALUMINUM COVER PLATE SEE SHEET DY10
- STEEL COVER PLATE SEE SHEET DY10
- EXP EXPANSION SPACER SEE DETAIL J/DY4

SEE SHEET T5 FOR PLATFORMS  
SEE SHEET T6 FOR GANGWAYS AND RAMPS

CONSTRUCTION

KEY

- L LOW FENDER SEE SHEET DY9
- H HIGH FENDER SEE SHEET DY9
- P BARGE TO BARGE PIN REQ'D

NOTE: SEE SHEET T1 FOR BARGE UNITS.  
SEE SHEET T2 FOR PILE GUIDE UNITS.

Reference Drawings

GENERAL NOTES:

ISSUED FOR: CONSTRUCTION 14/08/01

AMENDMENTS:

NO:	REVISION	APP	DATE:
Δ	COVER PLATE	RRB	04/01/02

SCALE: AS NOTED

SURVEY

PREPARED BY: DATE:

DESIGN

PREPARED BY: BAP DATE: 23/05/01

CHECKED BY: RRB

DATE: 23/05/01

DRAWING

PREPARED BY: JSK DATE: 23/05/01

CHECKED BY: BAP

DATE: 23/05/01

APPROVED BY: RRB

PROJECT NUMBER:

61/01/01

PROJECT NAME:

DOCKYARD  
REPLACEMENT FERRY PROJEC  
PHASE 1  
DOCK CONSTRUCTION

DOCKYARD TERRACE  
SANDYS PARISH

DRAWING FILE NO: ACAD R-14

DY-4 Assembly-Connections.dwg

SHEET TITLE:

ASSEMBLY  
CONNECTIONS

SHEET NUMBER:

61/45/01/DY4

REVISION

Δ

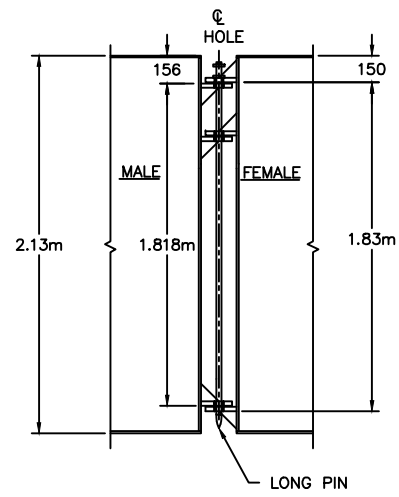

**A**  
HIGH BARGE CONNECTION  
DY4 SCALE: 1 : 20

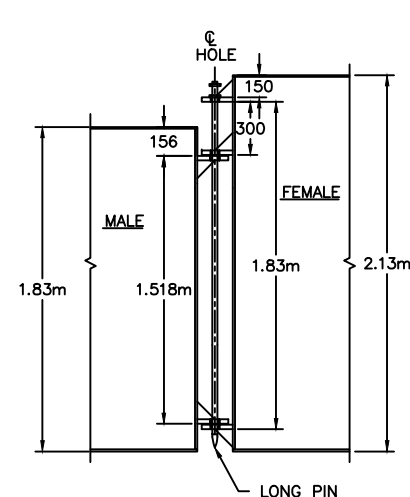

**B**  
HIGH/LOW BARGE CONNECTION  
DY4 SCALE: 1 : 20

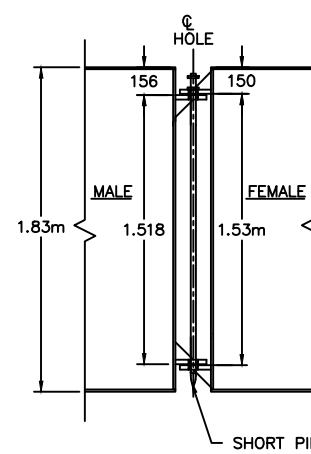

**C**  
LOW BARGE CONNECTION  
PILE GUIDE CONN. SIMILAR  
DY4 SCALE: 1 : 20

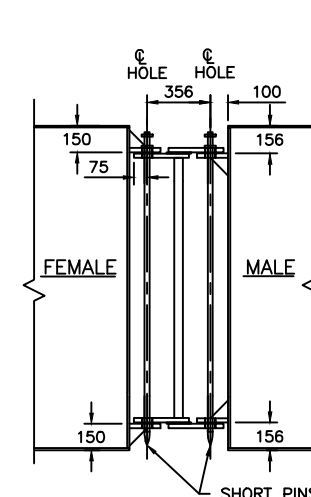

**D**  
BARGE CONNECTION - DETAIL  
DY4 SCALE: 1 : 20

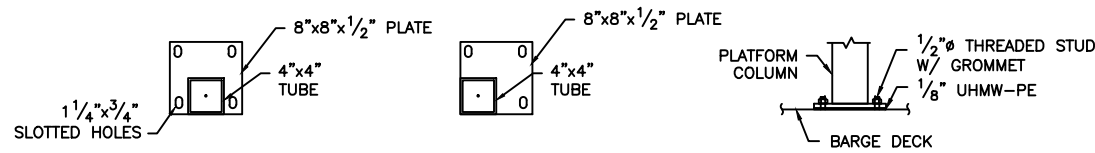

NOTE:  
CONNECTION SHALL BE 4-1/2" SS THD' STUDS W/GROMMET,  
NUT & WASHER WITH 1/8" x 9" UHMW-PE BELOW BASE PLATE

**E**  
PLATFORM BASE CONNECTION  
DY4 SCALE: 1 : 10

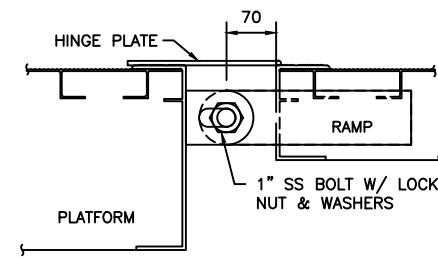

**F**  
RAMP TO PLATFORM CONNECTION  
DY4 SCALE: 1 : 5

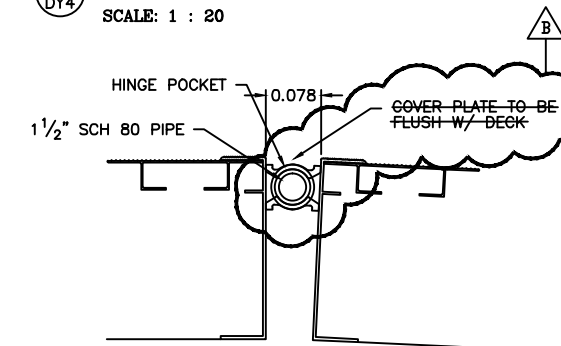

NOTE  
SECURE SCH 80 PIPE TO PREVENT LONGITUDINAL MOVEMENT

**G**  
STANDARD HINGE POCKET CONNECTION  
DY4 SCALE: 1 : 5

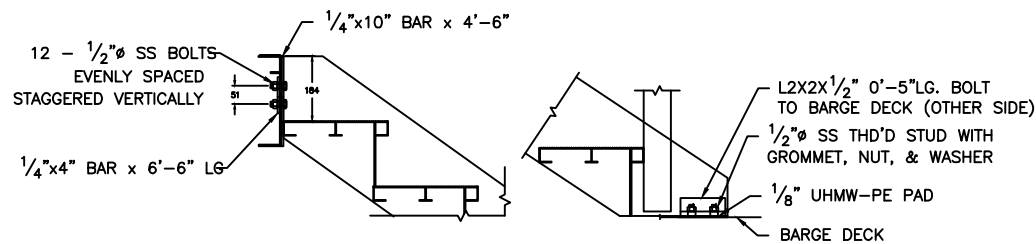

**H**  
STAIR CONNECTIONS  
DY4 SCALE: 1 : 10

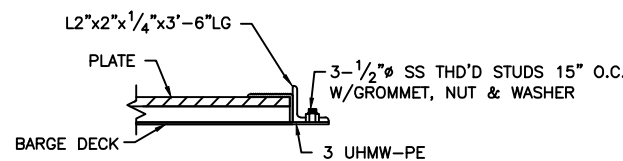

**I**  
TRANSITION CONNECTION  
DY4 SCALE: 1 : 5

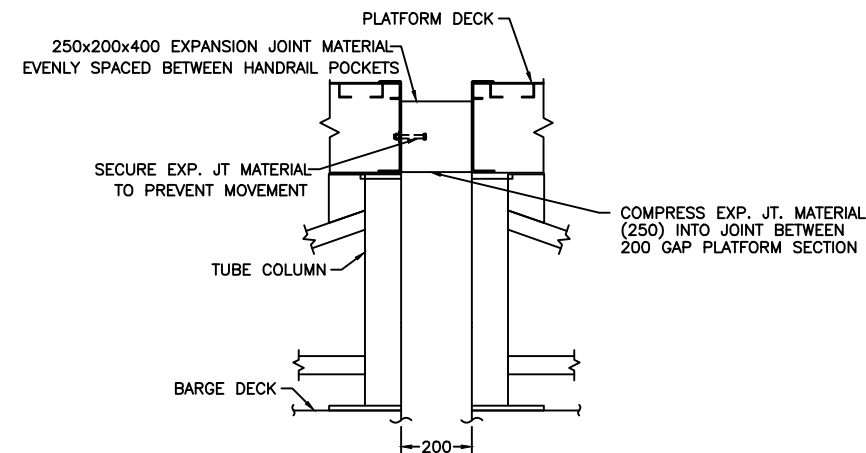

**J**  
PLATFORM TO PLATFORM CONNECTION  
DY4 SCALE: 1 : 10

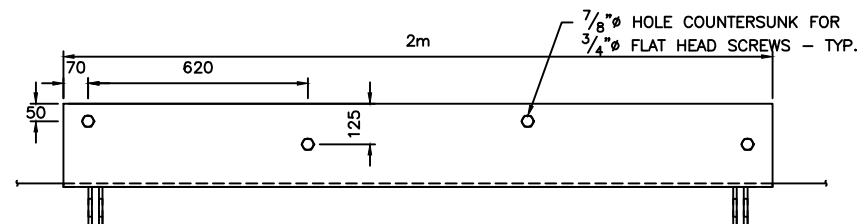

PLAN

**K**  
GANGWAY LANDSIDE CONNECTION - STANDARD DETAIL  
DY4 SCALE: 1 : 10

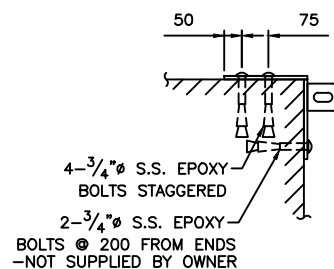

SECTION

CONSTRUCTION

Reference Drawings

Structures Section

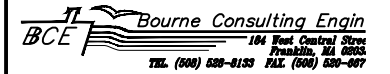

GENERAL NOTES:

NOTES:

1. BALLAST LOADS ARE SHOWN AT CENTER OF BAY UNLESS NOTED OTHERWISE.
2. BALLAST TO BE REMOVABLE CONCRETE BLOCK OR LEAD.
3. BALLAST SHALL BE INSTALLED ON TIMBER PALLETS AT LOCATIONS SHOWN. PALLET SUPPLIED W/ BARGES

ISSUED FOR: CONSTRUCTION 14/08/01

AMENDMENTS:

NO:	REVISION	APP	DATE:
1	HOOP ORIENTATION	RRB	04/01/02
2	BALLAST LAYOUT	RRB	11/02/02

SCALE: AS NOTED

SURVEY

PREPARED BY: DATE:

DESIGN

PREPARED BY: BAP DATE: 23/05/01  
CHECKED BY: RRB DATE: 23/05/01

DRAWING

PREPARED BY: JSK DATE: 23/05/01  
CHECKED BY: BAP DATE: 23/05/01

APPROVED BY: RRB

PROJECT NUMBER: 61/01/01

PROJECT NAME:

**DOCKYARD  
REPLACEMENT FERRY PROJEC  
PHASE 1  
DOCK CONSTRUCTION**

**DOCKYARD TERRACE  
SANDYS PARISH**

DRAWING FILE NO: ACAD R-14  
DY-05\_Ballasting Plan.dwg

SHEET TITLE:

**BALLASTING  
PLAN**

SHEET NUMBER: 61/45/01/DY5 REVISION:

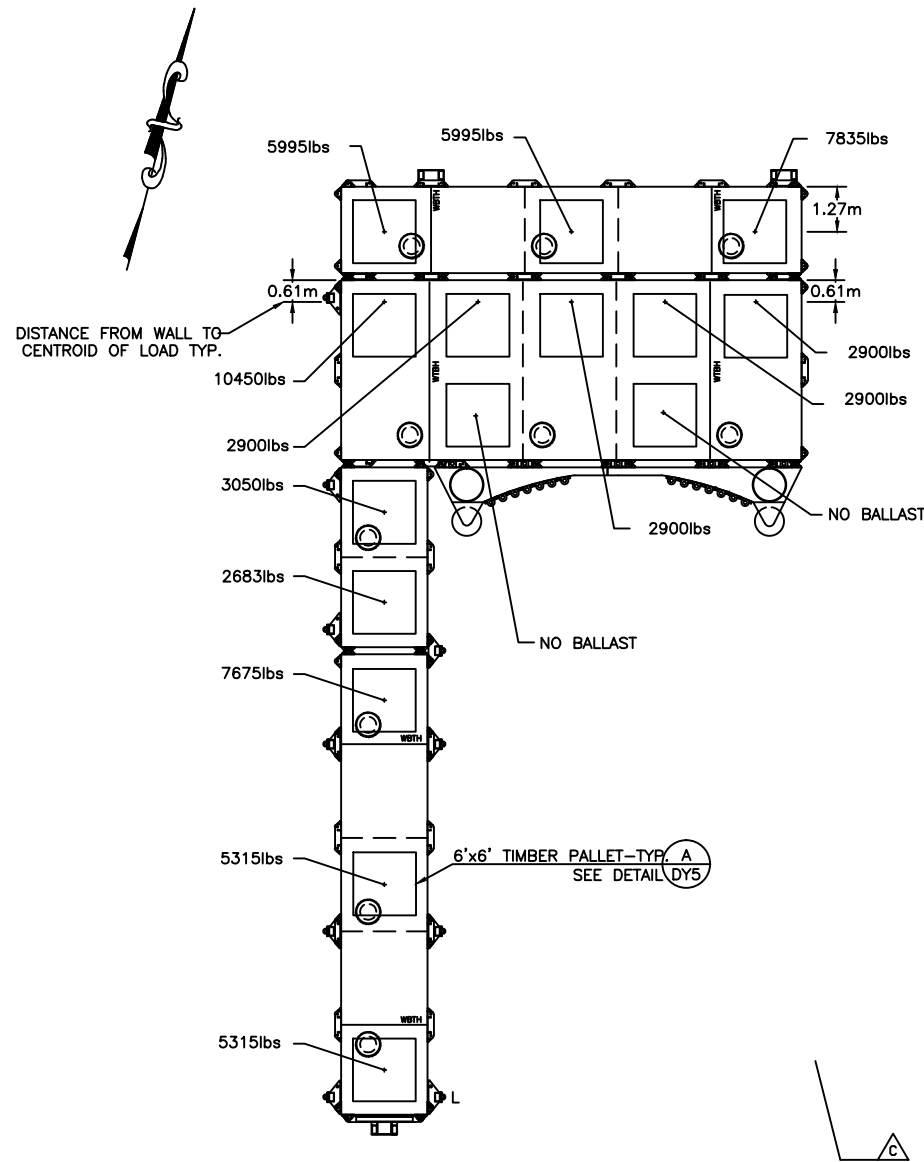

**DOCKYARD**

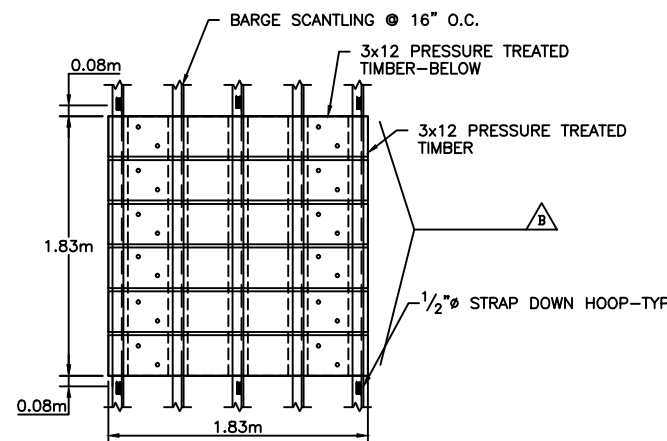

**BALLAST PALLET-PLAN**  
SCALE: 1 : 25

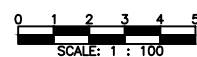

**CONSTRUCTION**  
**Reference Drawings**

Structures Section

GENERAL NOTES:

ISSUED FOR: CONSTRUCTION 14/08/01

AMENDMENTS:

NO:	REVISION	APP	DATE:

SCALE: AS NOTED

SURVEY  
PREPARED BY: DATE:

DESIGN  
PREPARED BY: DATE:  
BAP 23/05/01  
CHECKED BY: DATE:  
RRB 23/05/01

DRAWING  
PREPARED BY: DATE:  
BAP 23/05/01  
CHECKED BY: DATE:  
RRB 23/05/01

APPROVED BY:  
RRB

PROJECT NUMBER:  
61/01/01

PROJECT NAME:  
**DOCKYARD  
REPLACEMENT FERRY PROJEC  
PHASE 1  
DOCK CONSTRUCTION**

**DOCKYARD TERRACE  
SANDYS**

DRAWING FILE NO: ACAD R-14  
DY-6 Gangway Notch.dwg

SHEET TITLE:  
**GANGWAY NOTCH  
PLAN & DETAILS**

SHEET NUMBER:  
**61/45/01/DY6**

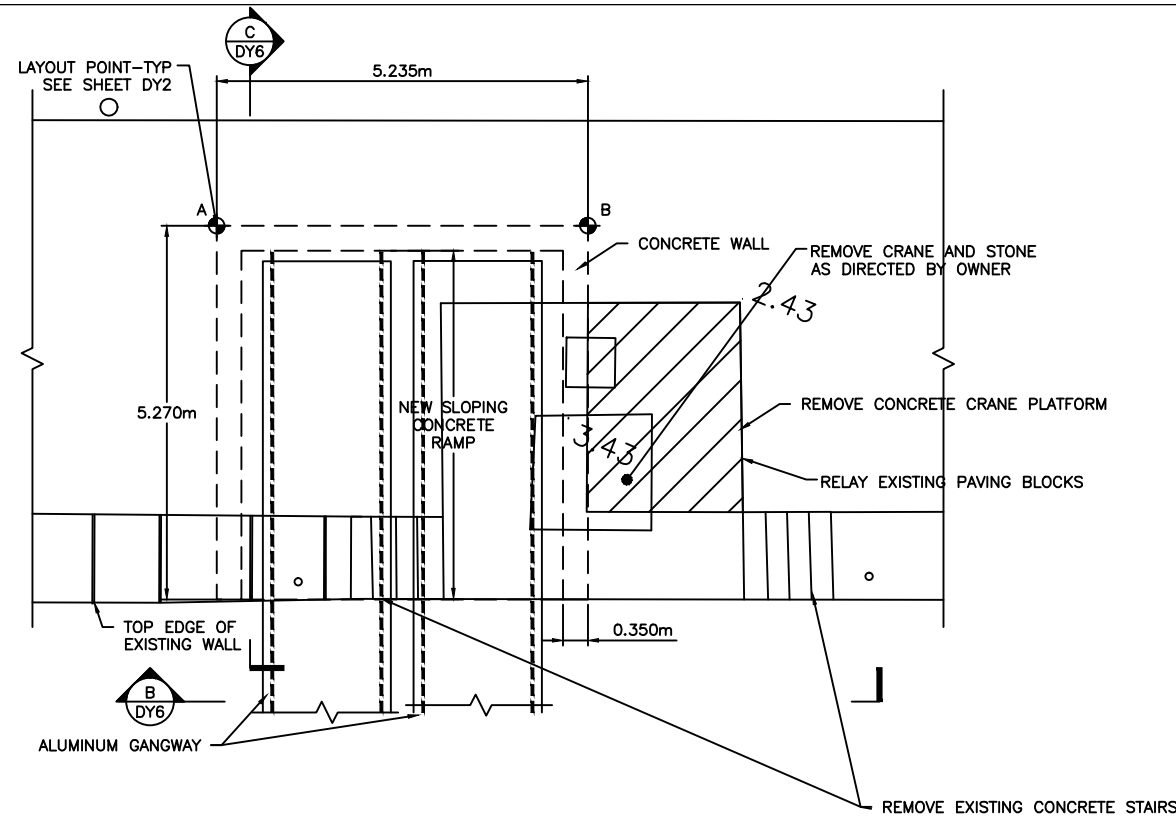

**CONCRETE NOTCH-PLAN**  
SCALE: 1 : 50

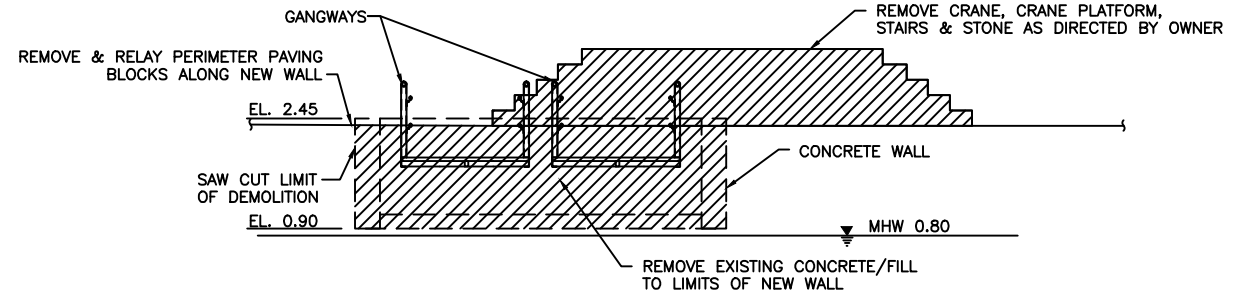

**CONCRETE NOTCH-ELEVATION**  
SCALE: 1 : 50

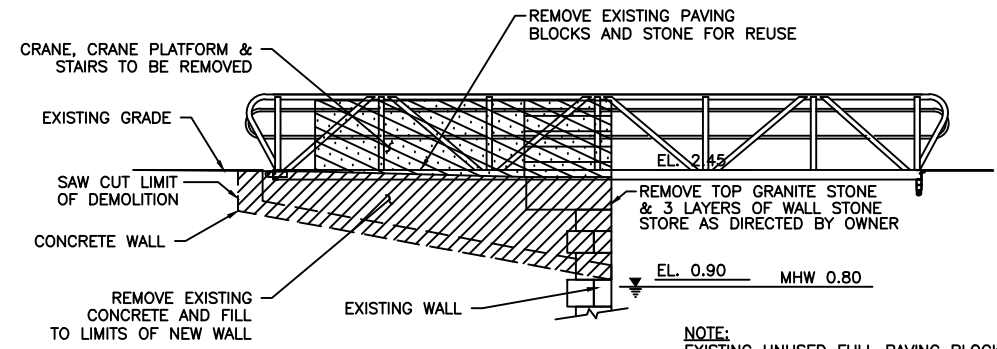

**CONCRETE NOTCH-SECTION**  
SCALE: 1 : 50

NOTE:  
NO CHAMFER @ GANGWAY LOCATIONS

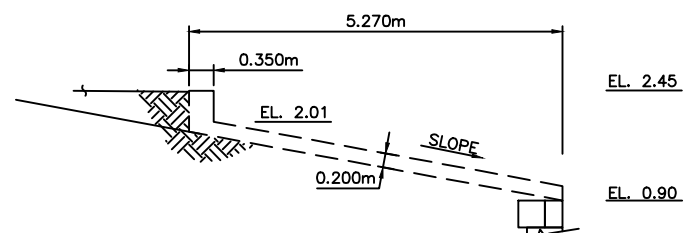

**CONCRETE WALL-ELEVATION**  
SCALE: 1 : 50

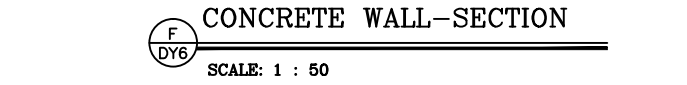

**CONCRETE WALL-SECTION**  
SCALE: 1 : 50

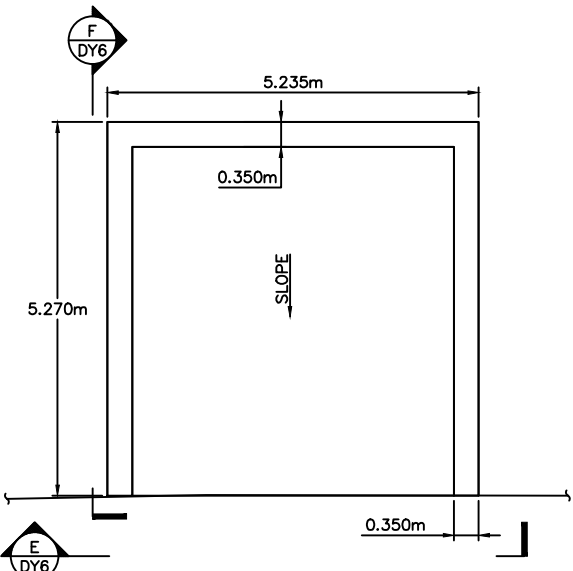

**CONCRETE WALL-PLAN**  
SCALE: 1 : 50

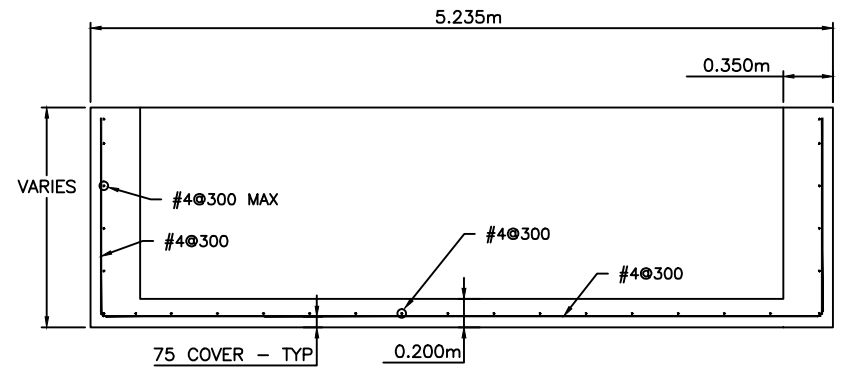

**CONCRETE WALL-REINFORCING**  
SCALE: 1 : 25

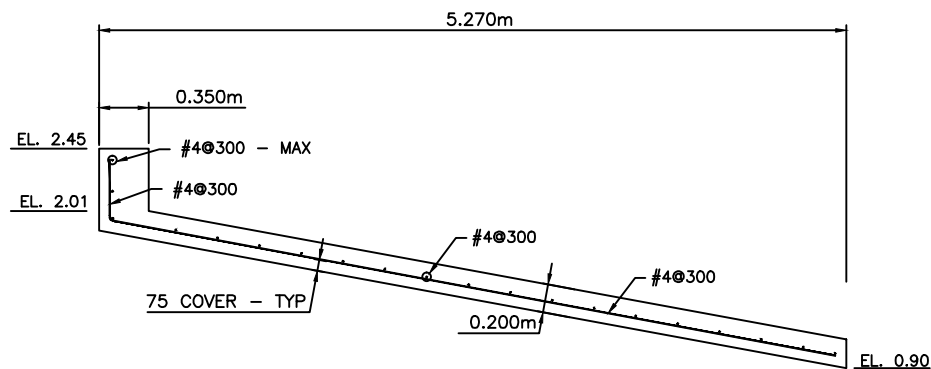

**TYPICAL SECTION - REINFORCING**  
SCALE: 1 : 25

- NOTE:
- \* TOP OF WALL ELEVATION +2.45
  - \* ALL REINFORCING MUST BE HOT DIPPED GALVANIZED.
  - \* MINIMUM COVER FOR REINFORCEMENT SHALL BE 75mm.
  - \* 25 CHAMFER ON ALL EXPOSED EDGES UNO

**CONSTRUCTION**

Reference Drawings

Structures Section



GENERAL NOTES:

ISSUED FOR: CONSTRUCTION 14/08/01

AMENDMENTS:

NO:	REVISION	APP	DATE:

SCALE: AS NOTED

SURVEY

PREPARED BY: DATE:

DESIGN

PREPARED BY: BAP DATE: 23/05/01

CHECKED BY: RRB DATE: 23/05/01

DRAWING

PREPARED BY: JSK DATE: 23/05/01

CHECKED BY: BAP DATE: 23/05/01

APPROVED BY: RRB

PROJECT NUMBER:  
61/01/01

PROJECT NAME:  
**DOCKYARD  
REPLACEMENT FERRY PROJEC  
PHASE 1  
DOCK CONSTRUCTION**

**DOCKYARD TERRACE  
SANDYS PARISH**

DRAWING FILE NO: ACAD R-14  
DY-07\_Wall-Fender.dwg

SHEET TITLE:

**WALL  
FENDER**

SHEET NUMBER: 61/45/01/DY7 REVISION:

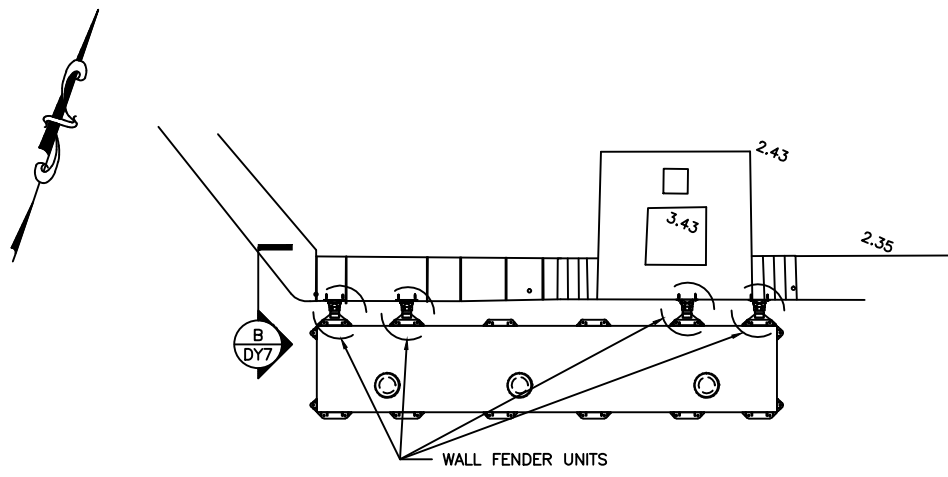

**A**  
PARTIAL PLAN  
SCALE: 1 : 50

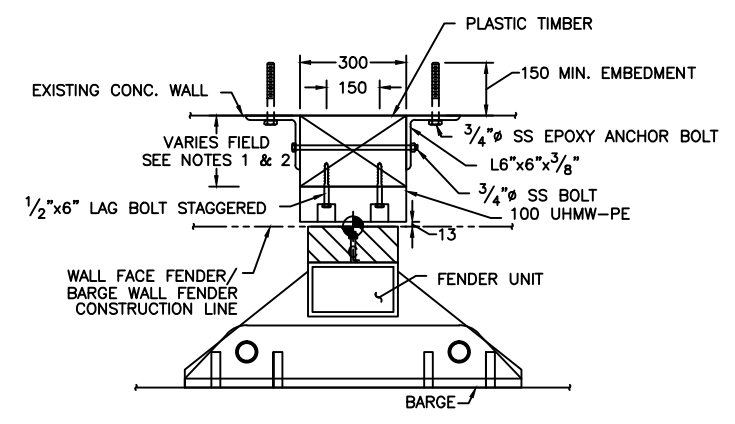

**C**  
WALL FENDER PLAN  
SCALE: 1 : 10

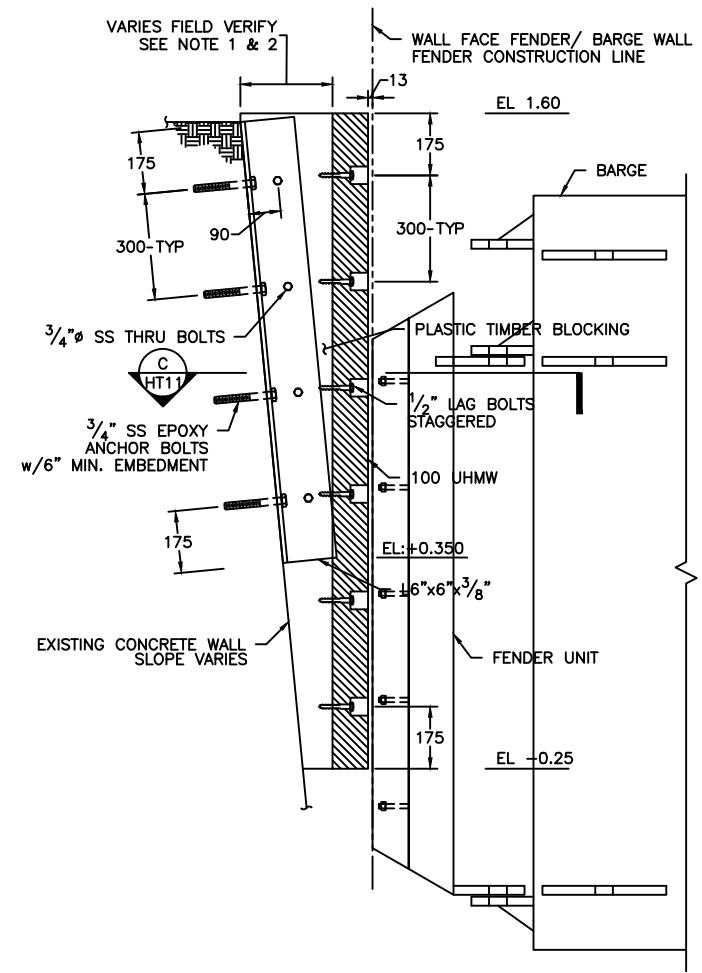

**B**  
WALL FENDER DETAIL  
SCALE: 1 : 10

- NOTES
1. PLASTIC TIMBER SHALL HAVE MINIMUM THICKNESS OF 100mm @ EL:+0.35.
  2. CONTRACTOR TO FIELD VERIFY SEA WALL SLOPE AND FINAL WALL FACE FENDER/BARGE WALL FENDER CONSTRUCTION LINE.

CONSTRUCTION  
**Reference Drawings**

Structures Section

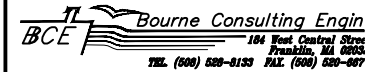

GENERAL NOTES:

ISSUED FOR: CONSTRUCTION 14/08/01

AMENDMENTS:

NO:	REVISION	APP	DATE:
Δ	DELETE MRG. DETAILS	RRB	04/01/02

SCALE: AS NOTED

SURVEY

PREPARED BY: DATE:

DESIGN

PREPARED BY: BAP DATE: 23/05/01

CHECKED BY: RRB DATE: 23/05/01

DRAWING

PREPARED BY: JSK DATE: 23/05/01

CHECKED BY: BAP DATE: 23/05/01

APPROVED BY: RRB

PROJECT NUMBER: 61/01/01

PROJECT NAME:

DOCKYARD

REPLACEMENT FERRY PROJEC

PHASE 1

DOCK CONSTRUCTION

DOCKYARD TERRACE

SANDYS PARISH

DRAWING FILE NO: ACAD R-14

DY-09Mooring Details

SHEET TITLE:

FENDER

DETAILS

SHEET NUMBER: 61/45/01/DY9

REVISION

Δ

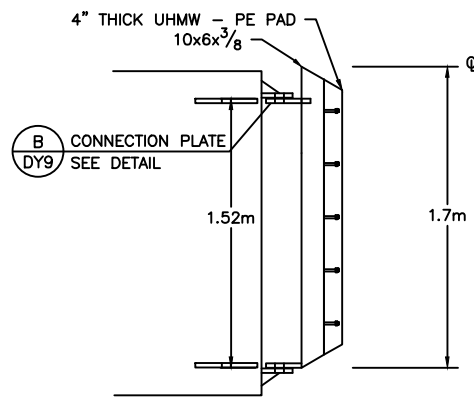

**WALL FENDER**  
SCALE: 1 : 20

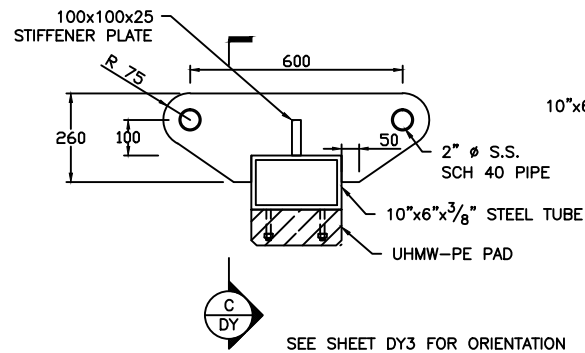

**WALL FENDER CONNECTION PLATE**  
SCALE: 1 : 10

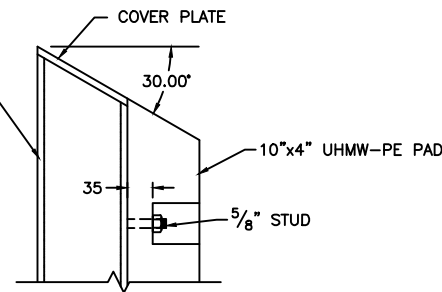

**SECTION**  
SCALE: 1 : 5

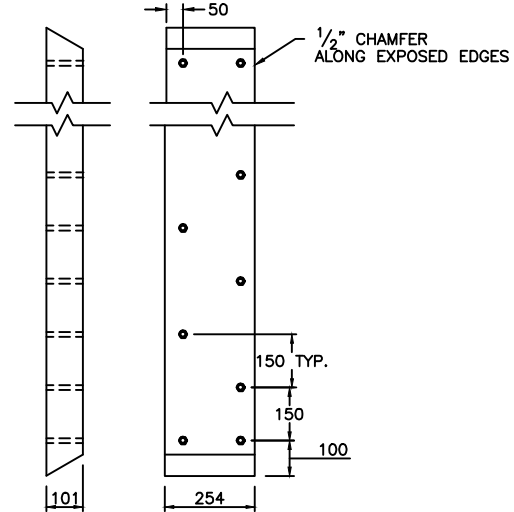

**UHMW-PE ELEVATIONS**  
SCALE: 1 : 10

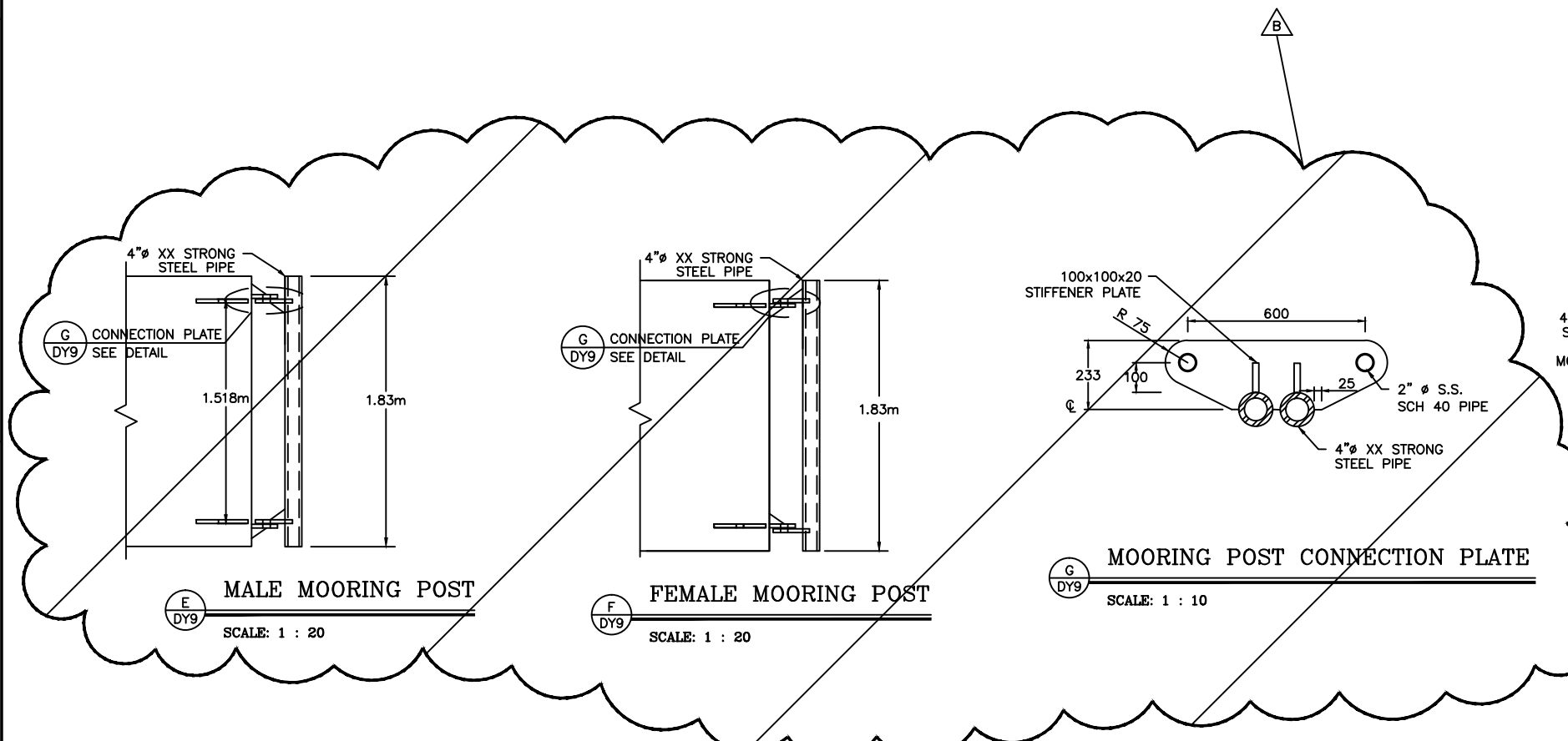

**MALE MOORING POST**  
SCALE: 1 : 20

**FEMALE MOORING POST**  
SCALE: 1 : 20

**MOORING POST CONNECTION PLATE**  
SCALE: 1 : 10

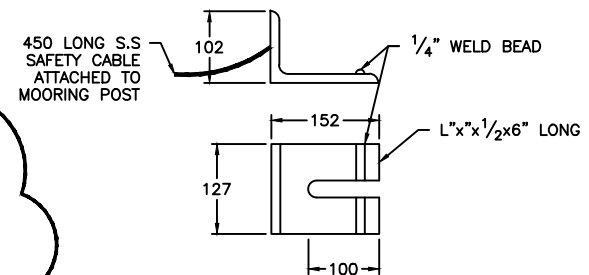

**3/4" Ø CHAIN DOG**  
SCALE: 1 : 5

CONSTRUCTION  
Reference Drawings

Structures Section

BCE Bourne Consulting Engin  
184 West Central Street  
Franklin, MA 02045  
TEL (508) 688-8133 FAX (508) 688-8077

GENERAL NOTES:

ISSUED FOR: CONSTRUCTION 14/08/01

AMENDMENTS:

NO.	REVISION	APP	DATE
1	TYPE I PLATE	RRB	04/01/02

SCALE: AS NOTED

SURVEY

PREPARED BY: DATE:

DESIGN

PREPARED BY: BAP DATE: 23/05/01

CHECKED BY: RRB

DATE: 23/05/01

DRAWING

PREPARED BY: JSK DATE: 23/05/01

CHECKED BY: BAP

DATE: 23/05/01

APPROVED BY: RRB

PROJECT NUMBER: 61/01/01

PROJECT NAME:

DOCKYARD  
REPLACEMENT FERRY PROJEC  
PHASE 1  
DOCK CONSTRUCTION

DOCKYARD TERRACE  
SANDYS PARISH

DRAWING FILE NO: ACAD R-14  
DY-10 Misc. Details.dwg

SHEET TITLE:

MISC.  
DETAILS

SHEET NUMBER: 61/45/01/DY10

REVISION

1

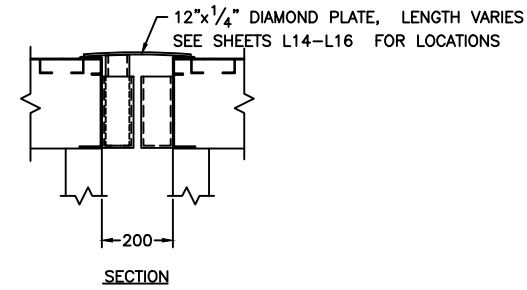

PLATFORM TO PLATFORM TRANSITION PLATE

SCALE: 1 : 10

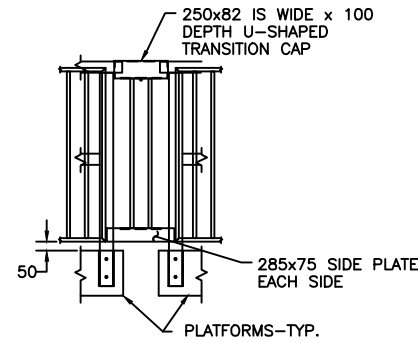

HANDRAIL CONNECTION

SCALE: 1 : 20

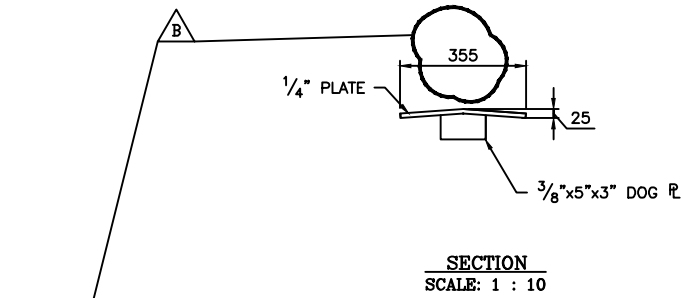

SECTION

SCALE: 1 : 10

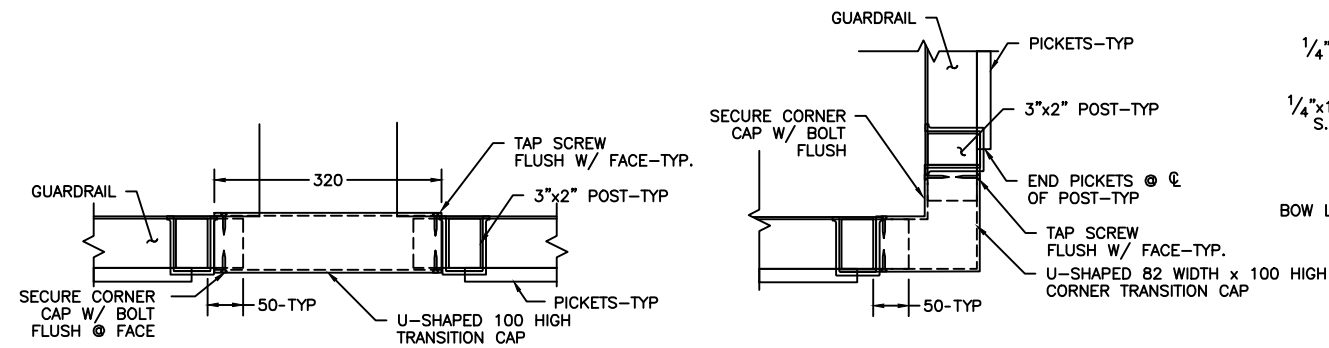

GUARDRAIL TRANSITION

SCALE: 1 : 5

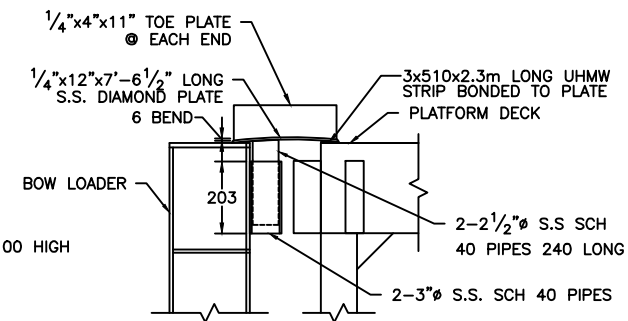

BOW LOADER COVER PLATE

SCALE: 1 : 10

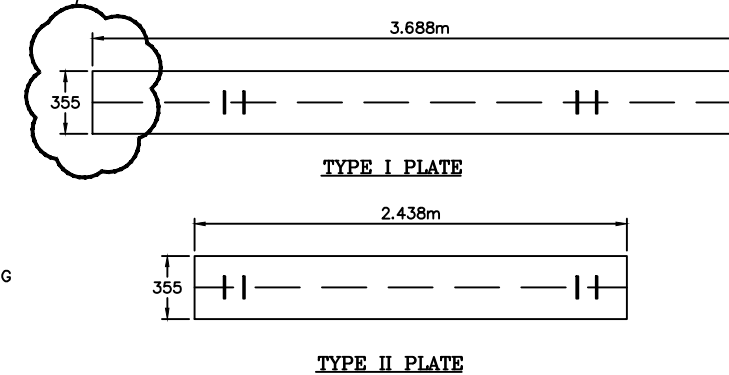

STEEL BARGE COVER PLATES

SCALE: 1 : 20

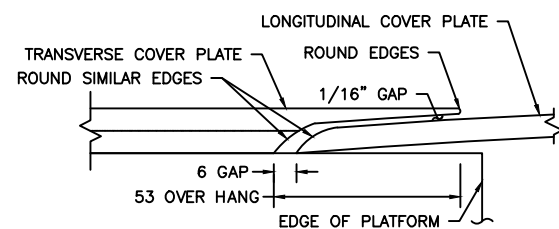

COVER PLATE CROSSING-SECTION

SCALE: 1 : 1

Reference Drawings

CONSTRUCTION



Structures Section



GENERAL NOTES:

ISSUED FOR: CONSTRUCTION 28/11/01

AMENDMENTS:

NO:	REVISION	APP	DATE:
△	SHEET ADDED	RRB	04/01/02
△	COORDINATES REVISED	DGF	22/02/02
△			
△			

SCALE: AS NOTED

SURVEY	
PREPARED BY:	DATE:
BAP	26/11/01
RRB	28/11/01

DRAWING	
PREPARED BY:	DATE:
BAP	26/11/01
RRB	28/11/01

APPROVED BY:  
RRB

PROJECT NUMBER:  
61/01/01

PROJECT NAME:  
**DOCKYARD  
REPLACEMENT FERRY PROJECT  
PHASE 1  
DOCK CONSTRUCTION**

**DOCKYARD TERRACE  
SANDYS PARISH**

DRAWING FILE NO: 21378/DY-11.dwg ACAD R-14

SHEET TITLE:  
**MOORING LAYOUT**

SHEET NUMBER: 61/45/01/DY11 REVISION: △

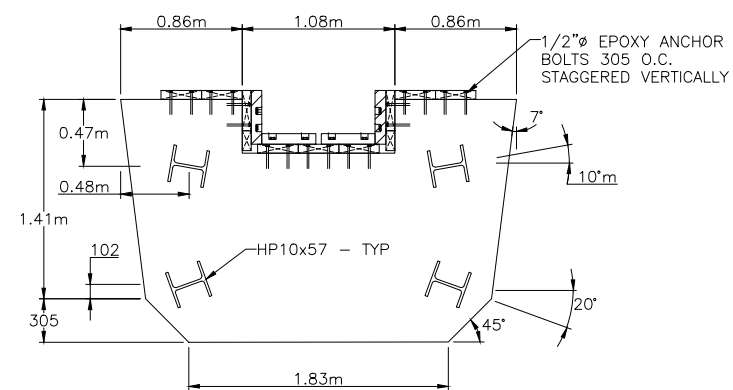

**A**  
MOORING PILE @ -0.2m - PLAN  
SCALE: 1 : 25

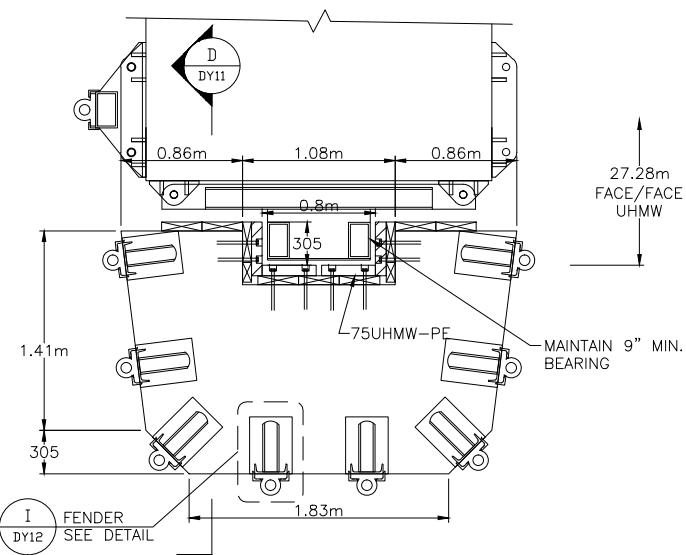

**B**  
MOORING PILE - PLAN  
SCALE: 1 : 25

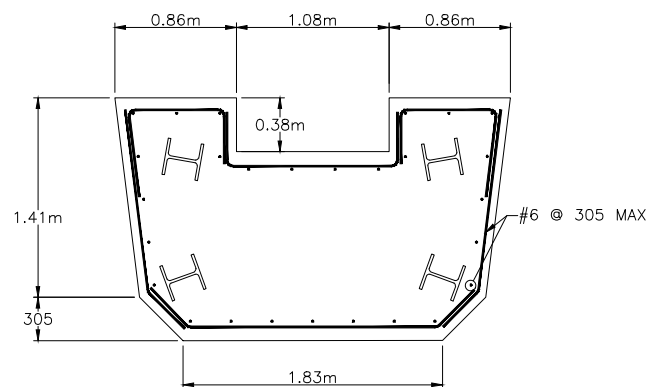

**C**  
REINFORCING - PLAN  
SCALE: 1 : 25

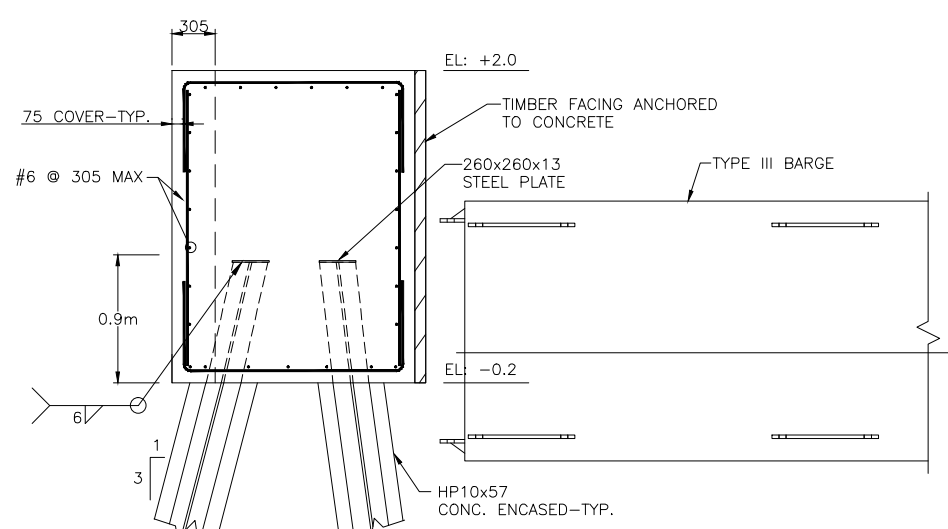
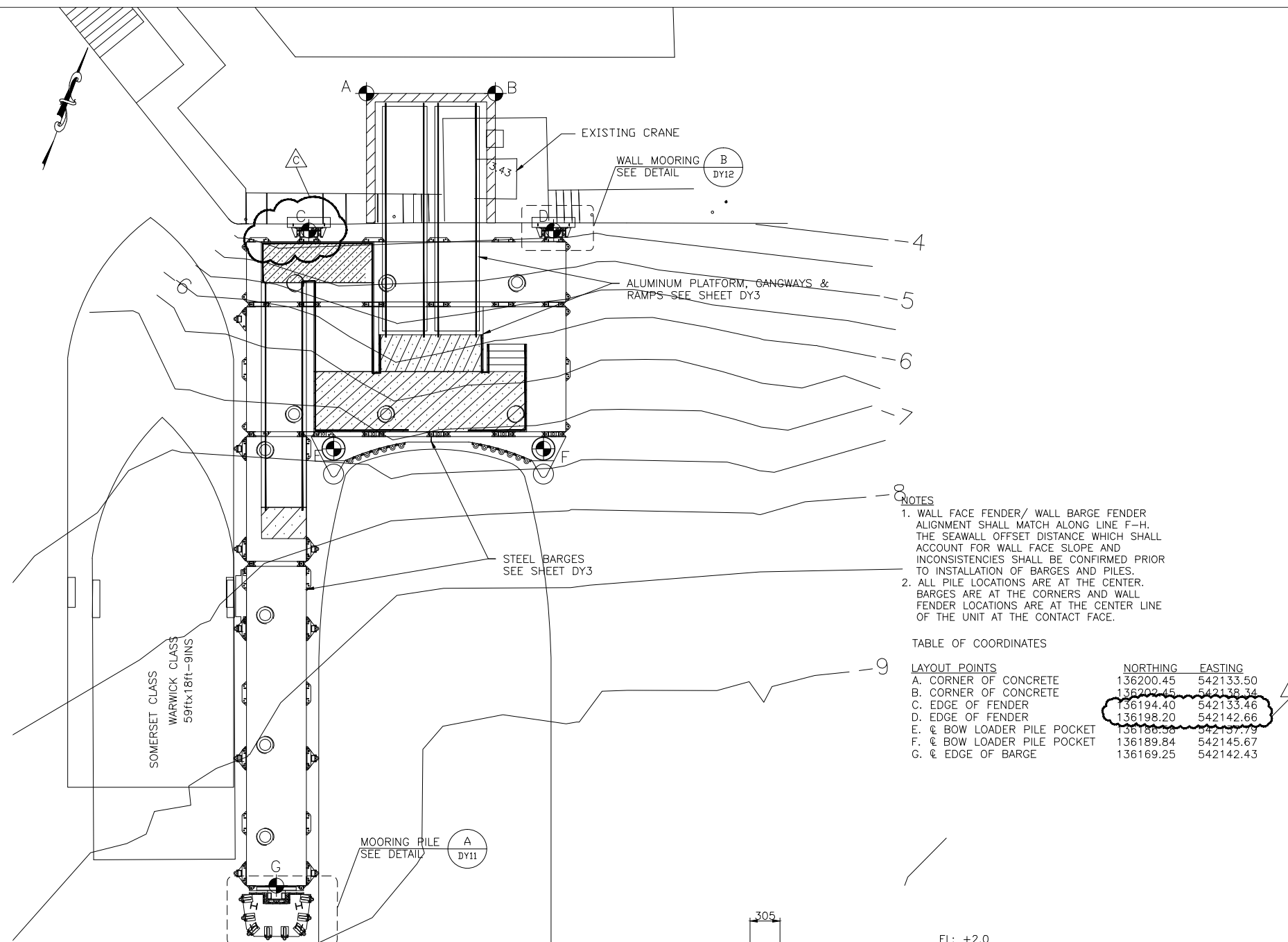

**D**  
MOORING PILE - SECTION  
SCALE: 1 : 25

THIS SHEET ADDED 14/12/01

Reference Drawings

Structures Section

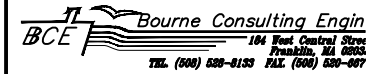

GENERAL NOTES:

ISSUED FOR: CONSTRUCTION 28/11/01

AMENDMENTS:

NO:	REVISION	APP	DATE:
Δ	SHEET ADDED	RRB	04/01/02

SCALE: AS NOTED

SURVEY  
PREPARED BY: DATE:

DESIGN  
PREPARED BY: BAP DATE: 26/11/01  
CHECKED BY: RRB DATE: 28/11/01

DRAWING  
PREPARED BY: JSK/BAP DATE: 26/11/01  
CHECKED BY: BAP DATE: 28/11/01

APPROVED BY: RRB

PROJECT NUMBER:  
61/01/01

PROJECT NAME:  
**DOCKYARD  
REPLACEMENT FERRY PROJEC**

**DOCK CONSTRUCTION  
DOCKYARD TERRACE  
SANDYS PARISH**

DRAWING FILE NO: ACAD R-14  
21378/DY-12.dwg

SHEET TITLE:  
**MOORING DETAILS**

SHEET NUMBER: 61/45/01 DY12

REVISION  
Δ

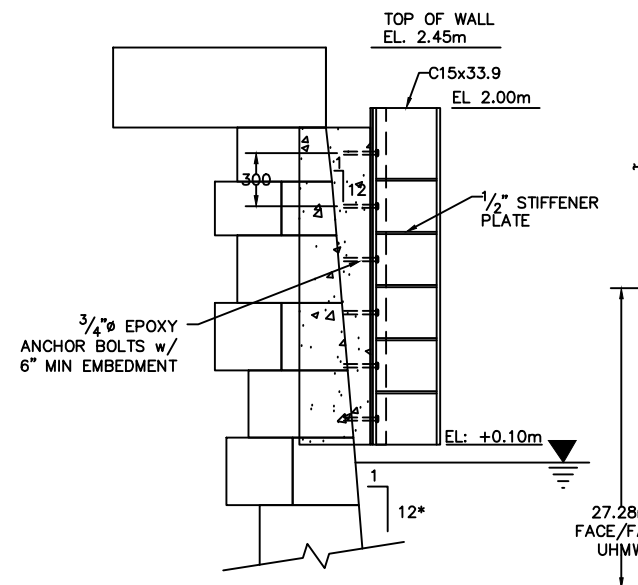

**A**  
WALL MOORING GUIDE-SECTION  
SCALE: 1 : 20

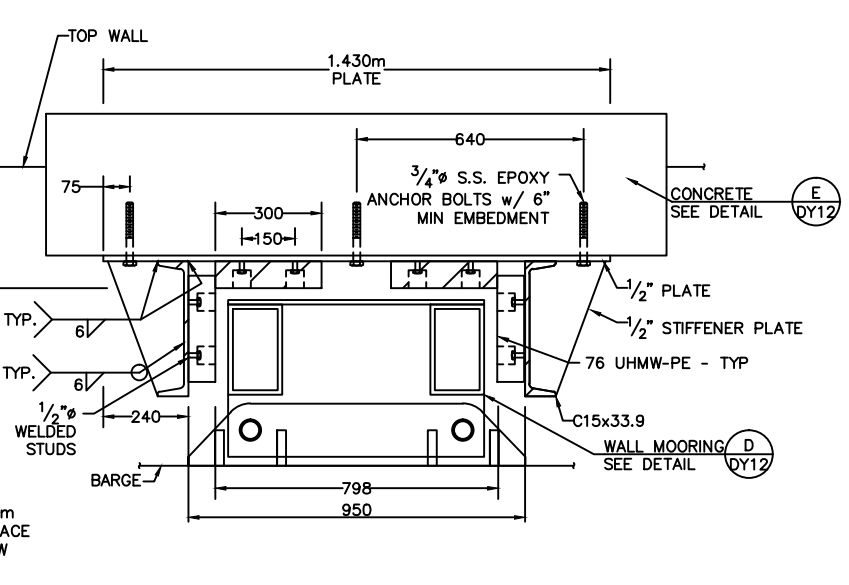

**B**  
WALL MOORING GUIDE-PLAN  
SCALE: 1 : 10

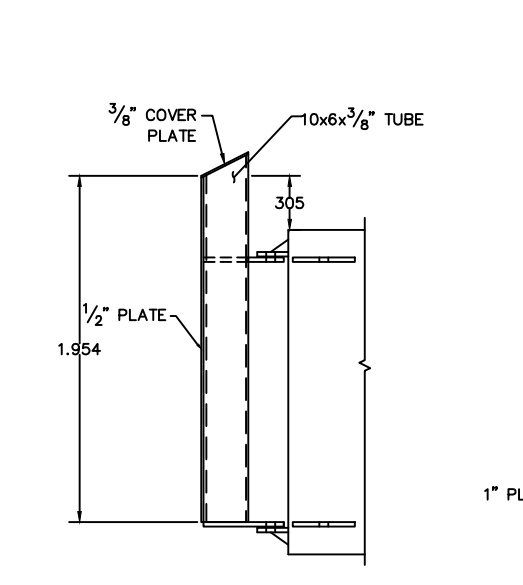

**C**  
MOORING ATTACHMENT @ WALL  
SCALE: 1 : 20

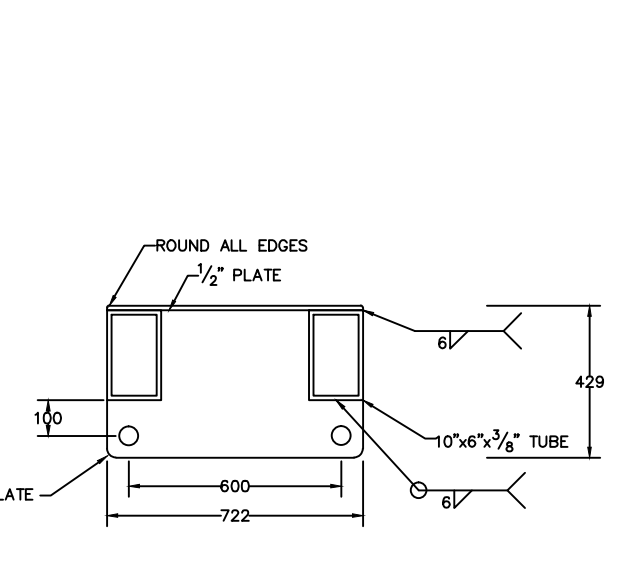

**D**  
WALL MOORING - PLAN  
SCALE: 1 : 10

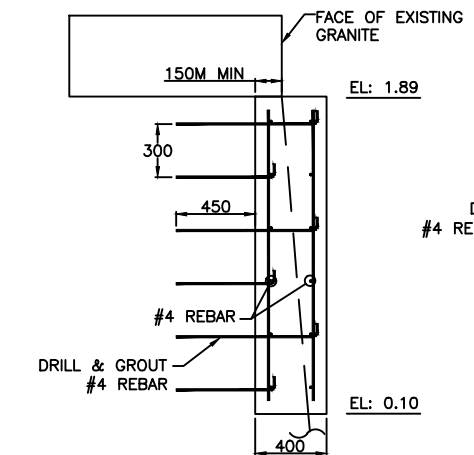

**E**  
MOORING TO WALL  
ATTACHMENT-SECTION  
SCALE: 1 : 20

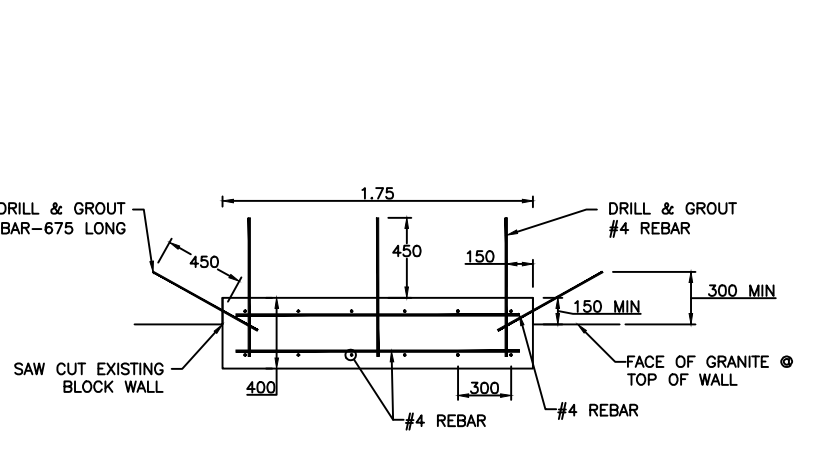

**F**  
MOORING TO WALL  
ATTACHMENT-PLAN  
SCALE: 1 : 20

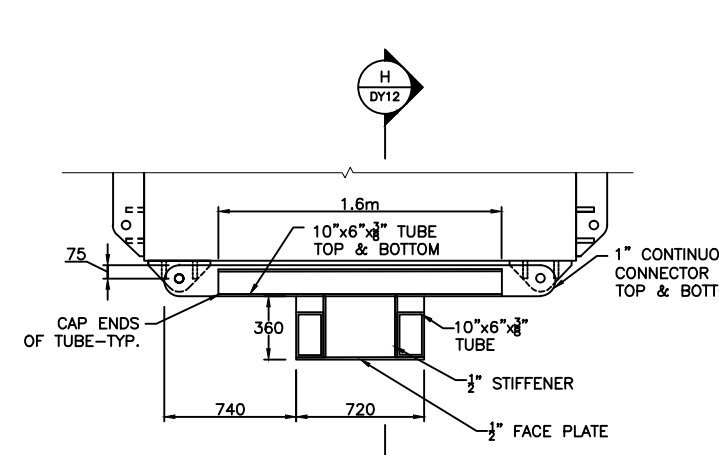

**G**  
BARGE/MOORING DOLPHIN-PLAN  
SCALE: 1 : 20

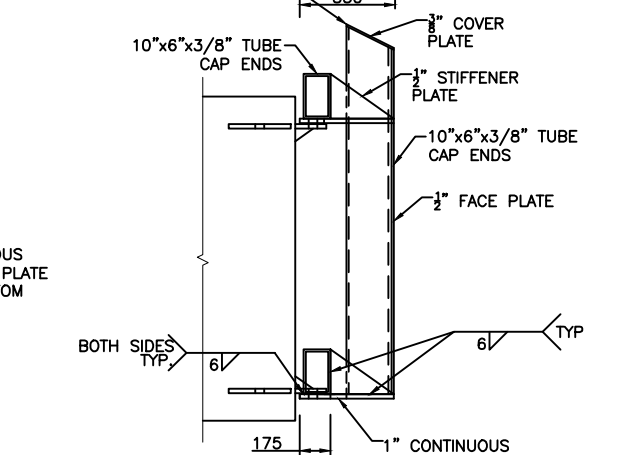

**H**  
BARGE/MOORING DOLPHIN-SECTION  
SCALE: 1 : 20

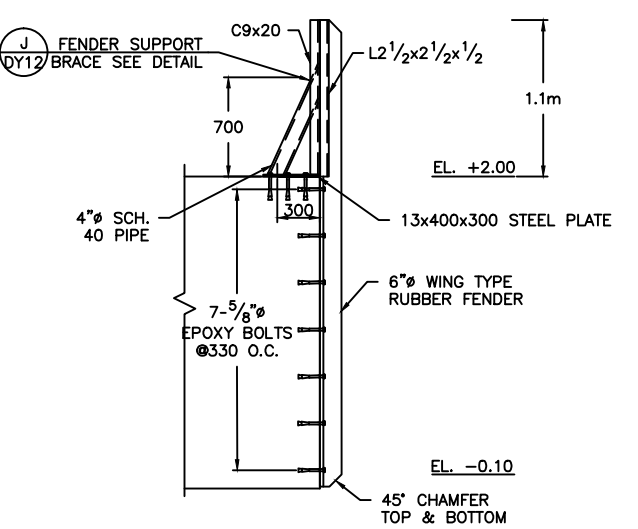

**I**  
FENDER SECTION  
SCALE: 1 : 25

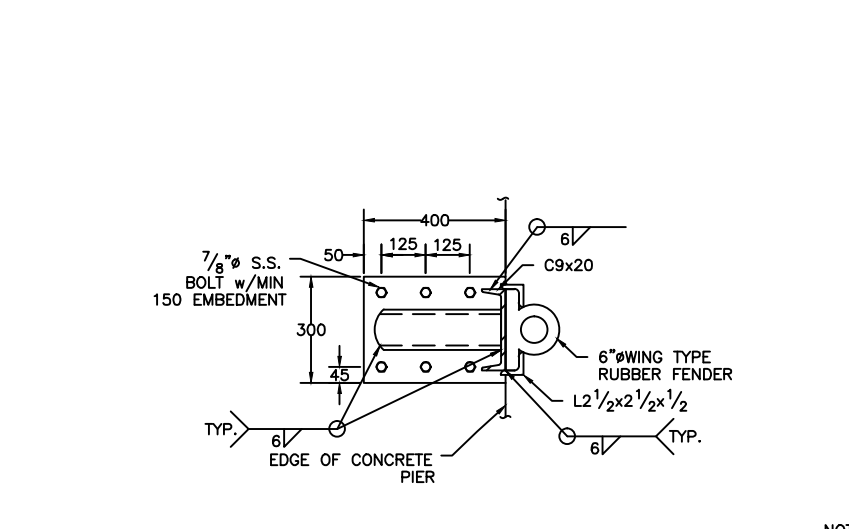

**J**  
FENDER SUPPORT BRACE  
SCALE: 1 : 10

- NOTES
1. CONTRACTOR TO FIELD VERIFY SEAWALL SLOPE
  2. STEEL ASSOCIATED WITH MOORING GUIDES AND ATTACHMENTS SHALL BE EPOXY COATED AS SPECIFIED
  3. STEEL FENDER SUPPORT BRACE SHALL BE GALVANIZED

Reference Drawings

Structures Section



- GENERAL NOTES:
1. COORDINATES BASED ON BNG 2000.
  2. ALL ELEVATIONS ARE IN METERS BASED ON ORDNANCE DATUM.
  3. ALL DISTANCES ARE IN METERS.
  4. SURVEY CONTROL SHALL BE PROVIDED TO THE CONTRACTOR BY THE OWNER.

ISSUED FOR: CONSTRUCTION 14/08/01

AMENDMENTS:

NO.	REVISION	APP	DATE:

SCALE: 1 : 200

SURVEY  
PREPARED BY: DATE:

DESIGN  
PREPARED BY: DATE:  
BAP 23/05/01  
CHECKED BY: DATE:  
RRB 23/05/01

DRAWING  
PREPARED BY: DATE:  
JSK 23/05/01  
CHECKED BY: DATE:  
BAP 23/05/01

APPROVED BY:  
RRB

PROJECT NUMBER:  
61/01/01

PROJECT NAME:  
**St. GEORGE'S  
REPLACEMENT FERRY PROJECT  
PHASE 1  
DOCK CONSTRUCTION**

**MARKET WHARF  
St. GEORGE'S PARISH**  
DRAWING FILE NO: ACAD R-14  
SG-1 Existing Cond.dwg

SHEET TITLE:  
**EXISTING  
CONDITIONS**

SHEET NUMBER: 61/46/01/SG1  
REVISION:

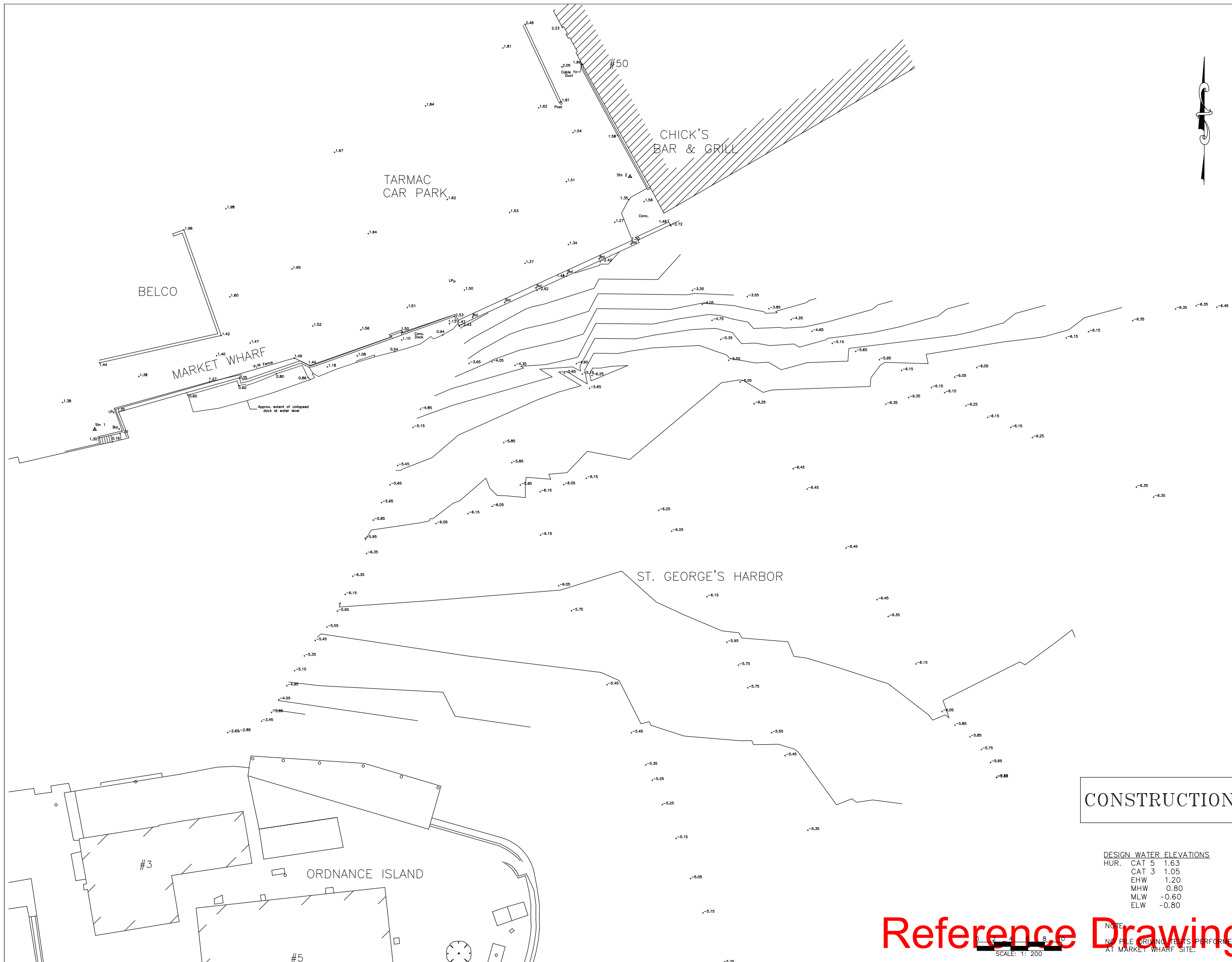

**CONSTRUCTION**

DESIGN WATER ELEVATIONS

HUR. CAT 5	1.63
CAT 3	1.05
EHW	1.20
MHW	0.80
MLW	-0.60
ELW	-0.80

**Reference Drawings**

NOTE:  
NO PILE DRIVING TESTS PERFORMED  
AT MARKET WHARF SITE.

SCALE: 1: 200

Structures Section

- GENERAL NOTES:
1. COORDINATES BASED ON BNG 2000.
  2. ALL ELEVATIONS ARE IN METERS BASED ON ORDNANCE DATUM.
  3. ALL DISTANCES ARE IN METERS.
  4. SURVEY CONTROL SHALL BE PROVIDED TO THE CONTRACTOR BY THE OWNER.

ISSUED FOR: CONSTRUCTION 14/08/01

AMENDMENTS:

NO:	REVISION	APP	DATE:
△	BARGE II	RRB	04/01/02
△	LAYOUT CHANGED	RJT	23/05/02

SCALE: 1 : 100

SURVEY

PREPARED BY: DATE:

DESIGN

PREPARED BY: DATE:  
BAP 23/05/01  
CHECKED BY: DATE:  
RRB 23/05/01

DRAWING

PREPARED BY: DATE:  
JSK 23/05/01  
CHECKED BY: DATE:  
BAP 23/05/01

APPROVED BY:  
RRB

PROJECT NUMBER:  
61/01/01

PROJECT NAME:  
**ST. GEORGE'S  
REPLACEMENT FERRY PROJECT  
PHASE 1  
DOCK CONSTRUCTION**

**MARKET WHARF  
ST. GEORGE'S PARISH**

DRAWING FILE NO: ACAD R-14  
SG-2 SITE LAYOUT.dwg

SHEET TITLE:

**SITE  
LAYOUT**

SHEET NUMBER: REVISION  
61/46/01/SG2

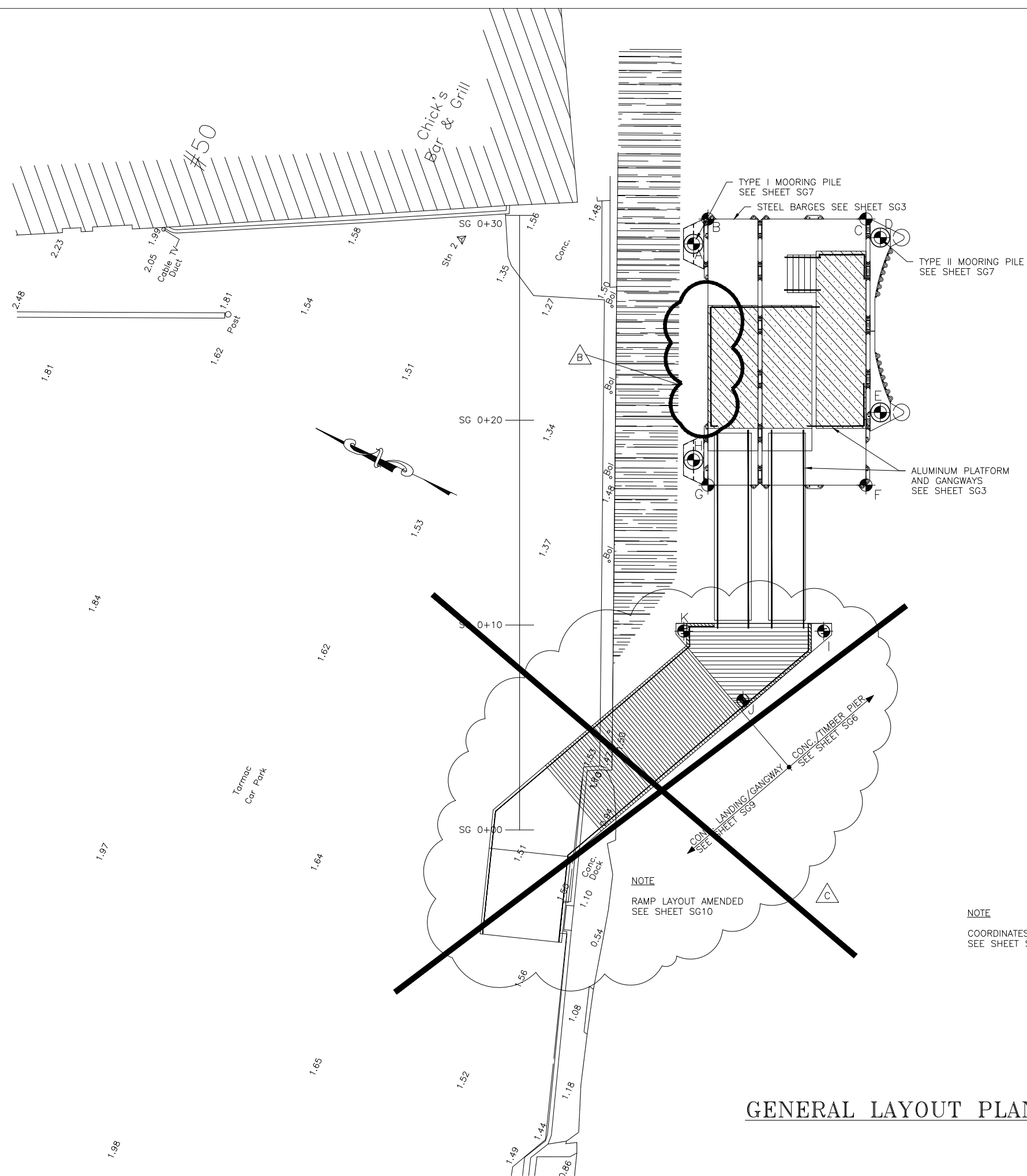

NOTE

1. ALL PILE LOCATIONS ARE AT THE CENTER.  
BARGE LOCATIONS ARE AT THE CORNERS.

NOTE

COORDINATES AMENDED  
SEE SHEET SG11

△ — LAYOUT POINT

TABLE OF COORDINATES

LAYOUT POINTS	NORTHING	EASTING
SG 0+00	142258.262	557003.180
SG 0+30	142271.064	557030.312
A. C. OF PILE	142262.788	557032.672
B. N.E. BARGE CORNER	142267.880	557034.074
C. S.E. BARGE CORNER	142285.704	557037.365
D. C. OF PILE	142254.682	557036.840
E. C. OF PILE	142251.042	557029.124
F. S.W. BARGE CORNER	142250.161	557025.617
G. N.W. BARGE CORNER	142257.137	557022.326
H. C. OF PILE	142257.291	557023.130
I. C. OF PILE	142248.581	557018.287
J. C. OF PILE	142251.108	557013.552
K. C. OF PILE	142255.159	557015.373

GENERAL LAYOUT PLAN

Reference Drawings

CONSTRUCTION

Structures Section



GENERAL NOTES:

ISSUED FOR: CONSTRUCTION 14/08/01

AMENDMENTS:

NO:	REVISION	APP	DATE:
△	BARGE II	RRB	04/01/02
△	PLATFORM AMENDED	RJT	23/05/02

SCALE: 1 : 100

SURVEY  
PREPARED BY: DATE:

DESIGN  
PREPARED BY: DATE: 23/05/01  
BAP  
CHECKED BY: DATE: 23/05/01  
RRB

DRAWING  
PREPARED BY: DATE: 23/05/01  
JSK  
CHECKED BY: DATE: 23/05/01  
BAP

APPROVED BY:  
RRB

PROJECT NUMBER:  
61/01/01

PROJECT NAME:  
**St. GEORGE'S  
REPLACEMENT FERRY PROJECT  
PHASE 1  
DOCK CONSTRUCTION**

**MARKET WHARF  
St. GEORGE'S PARISH**

DRAWING FILE NO: ACAD R-14  
SG-3 Barge & Assembly Plan.dwg

SHEET TITLE:  
**BARGE & ALUMINUM  
ASSEMBLY PLAN**

SHEET NUMBER:  
61/46/01/SG3

REVISION  
C

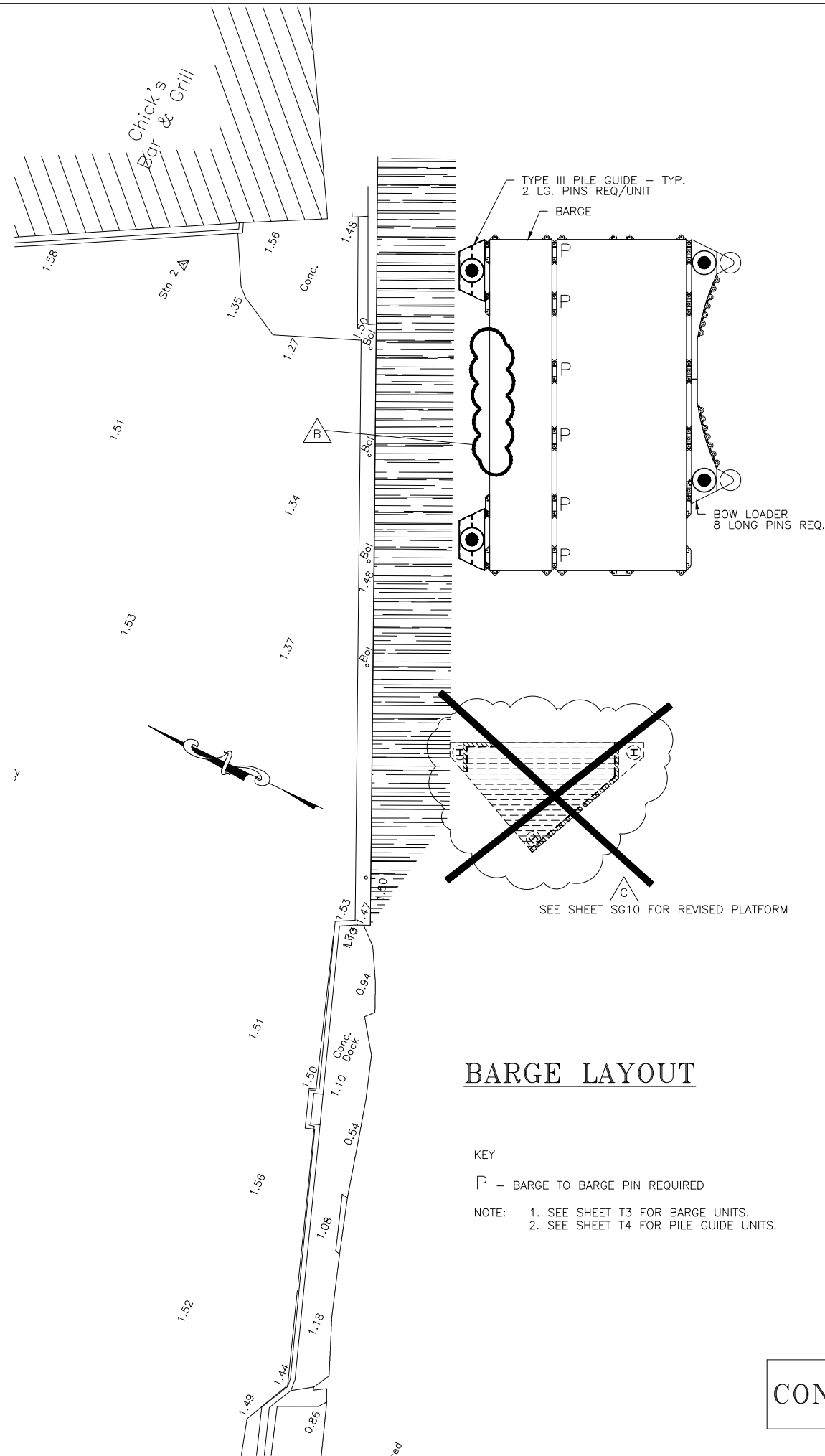

**BARGE LAYOUT**

KEY  
P - BARGE TO BARGE PIN REQUIRED  
NOTE: 1. SEE SHEET T3 FOR BARGE UNITS.  
2. SEE SHEET T4 FOR PILE GUIDE UNITS.

CONSTRUCTION

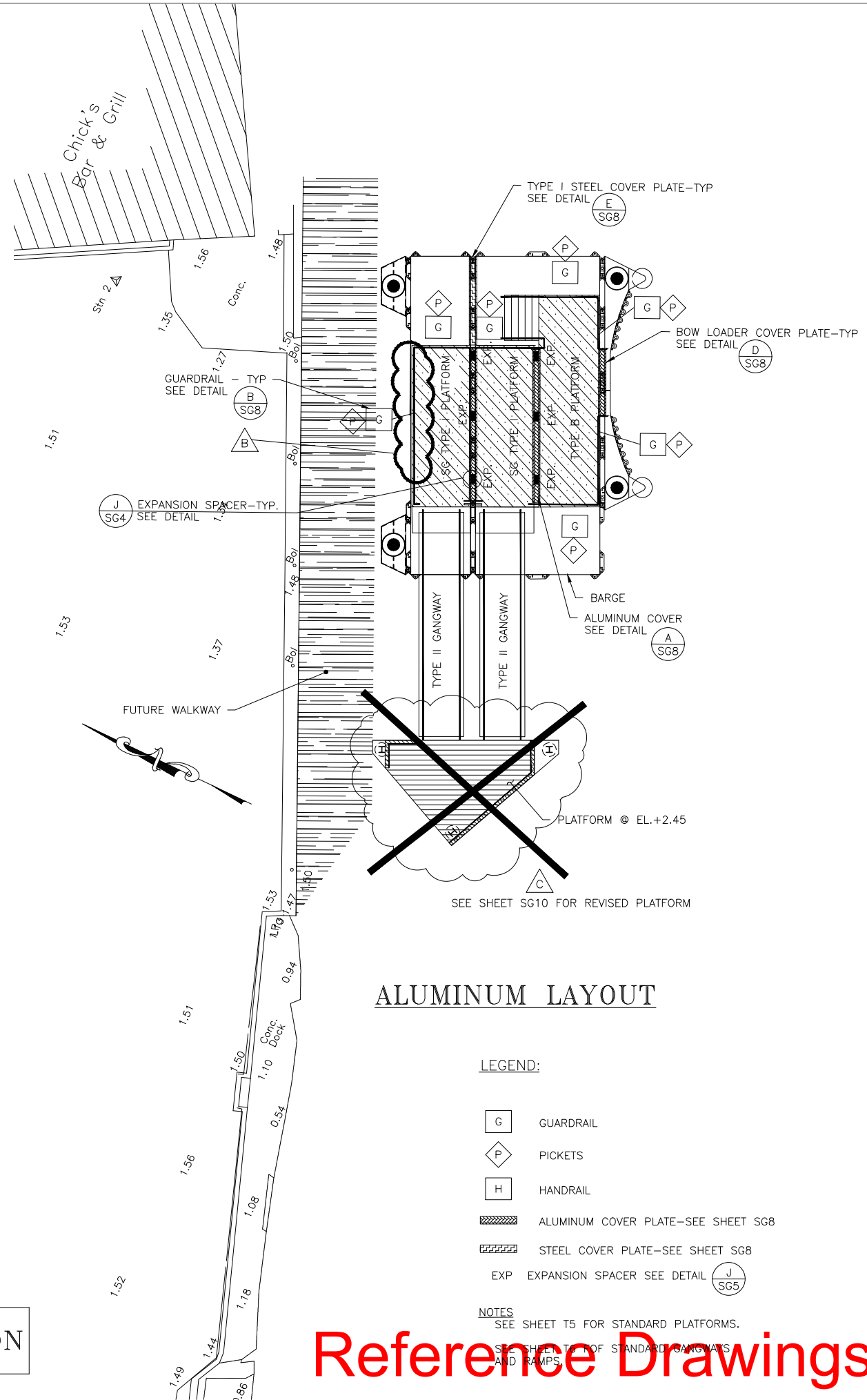

**ALUMINUM LAYOUT**

LEGEND:

- G GUARDRAIL
- P PICKETS
- H HANDRAIL
- ALUMINUM COVER PLATE-SEE SHEET SGB
- STEEL COVER PLATE-SEE SHEET SGB
- EXP EXPANSION SPACER SEE DETAIL (J SG5)

NOTES  
SEE SHEET T5 FOR STANDARD PLATFORMS.

SEE SHEET T4 FOR STANDARD GANGWAYS AND RAMP.

Reference Drawings

GENERAL NOTES:

ISSUED FOR: CONSTRUCTION 14/08/01

AMENDMENTS:

NO:	REVISION	APP	DATE:
1	COVER PLATE	RRB	04/01/02

SCALE: AS NOTED

SURVEY

PREPARED BY: DATE:

DESIGN

PREPARED BY: BAP DATE: 23/05/01

CHECKED BY: RRB

DATE: 23/05/01

DRAWING

PREPARED BY: JSK DATE: 23/05/01

CHECKED BY: BAP

DATE: 23/05/01

APPROVED BY: RRB

PROJECT NUMBER:

61/01/01

PROJECT NAME:

St. GEORGE'S  
REPLACEMENT FERRY PROJEC  
PHASE 1  
DOCK CONSTRUCTION

MARKET WHARF  
St. GEORGE'S PARISH

DRAWING FILE NO: ACAD R-14

SG-4 ASSEMBLY-CONN.DWG

SHEET TITLE:

ASSEMBLY  
CONNECTION

SHEET NUMBER:

61/46/01/SG4

REVISION

1

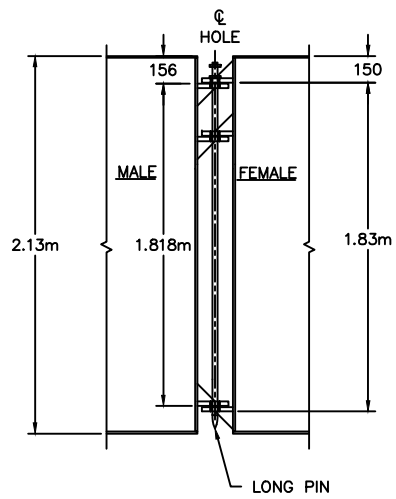

**A**  
SG4  
**HIGH BARGE CONNECTION**  
SCALE: 1 : 20

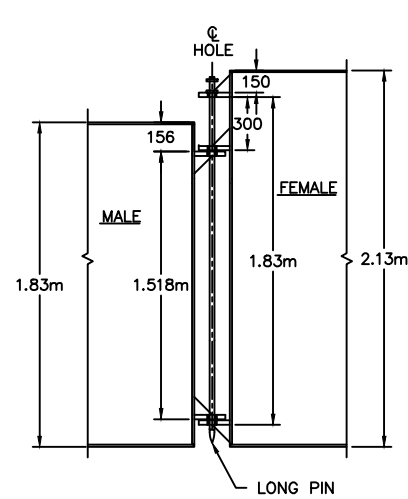

**B**  
SG4  
**HIGH/LOW BARGE CONNECTION**  
SCALE: 1 : 20

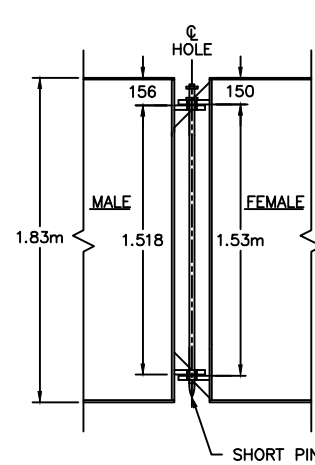

**C**  
SG4  
**LOW BARGE CONNECTION**  
PILE GUIDE CONN. SIMILAR  
SCALE: 1 : 20

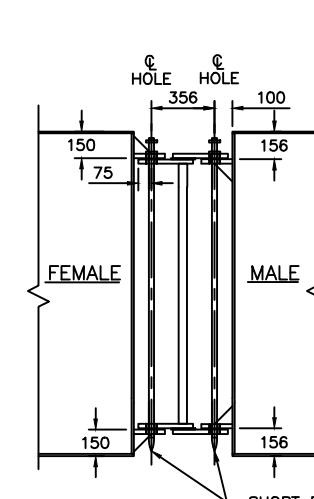

**D**  
SG4  
**BARGE CONNECTION - DETAIL**  
SCALE: 1 : 20

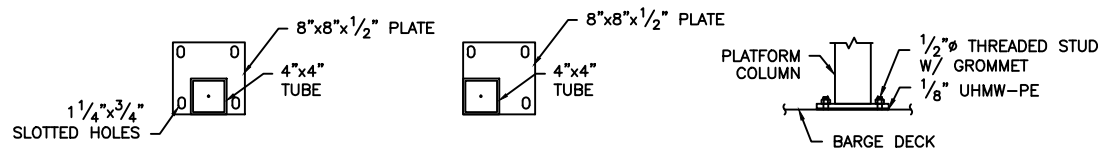

NOTE:  
CONNECTION SHALL BE 4-1/2" SS THD' STUDS W/GROMMET,  
NUT & WASHER WITH 1/8" x 9" x 9" UHMW-PE BELOW BASE PLATE

**E**  
SG4  
**PLATFORM BASE CONNECTION**  
SCALE: 1 : 10

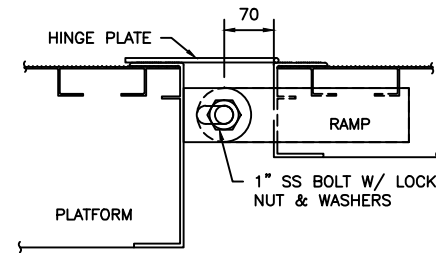

**F**  
SG4  
**RAMP TO PLATFORM CONNECTION**  
SCALE: 1 : 5

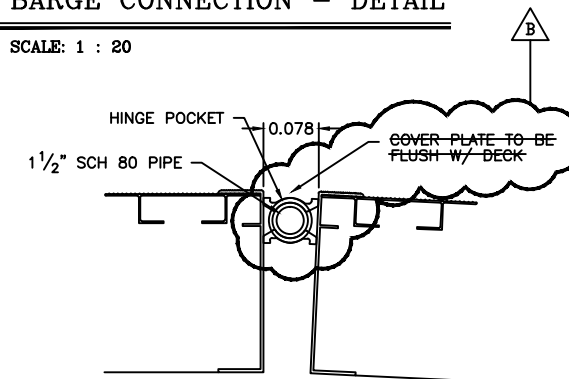

NOTE  
SECURE SCH 80 PIPE TO PREVENT LONGITUDINAL MOVEMENT

**G**  
SG4  
**STANDARD HINGE POCKET CONNECTION**  
SCALE: 1 : 5

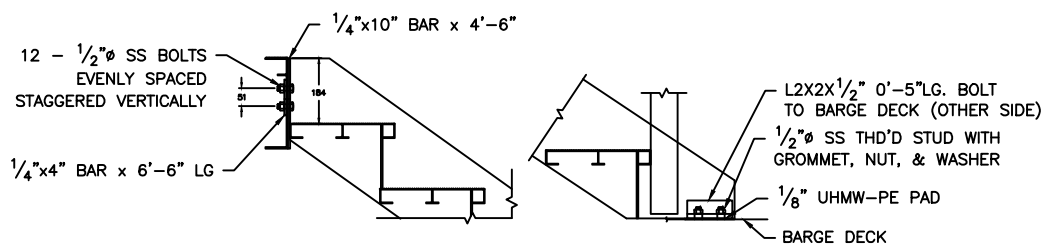

**H**  
SG4  
**STAIR CONNECTIONS**  
SCALE: 1 : 10

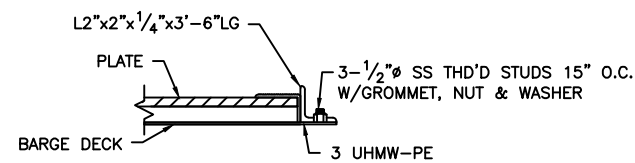

**I**  
SG4  
**TRANSITION CONNECTION**  
SCALE: 1 : 5

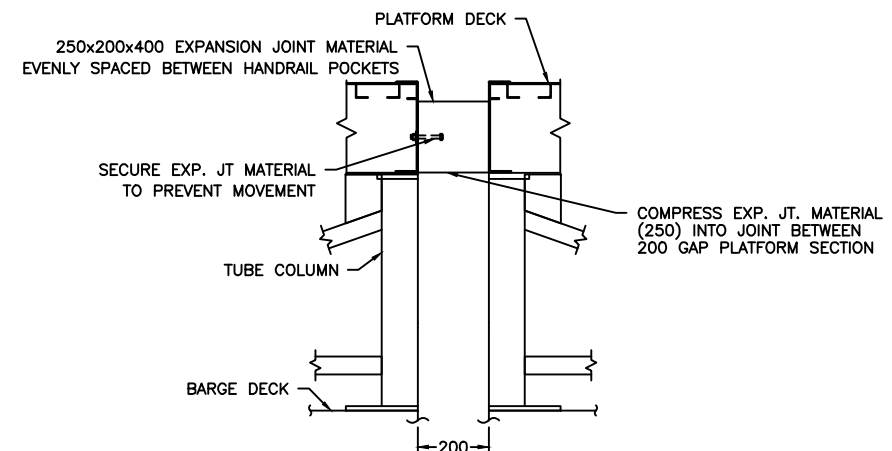

**J**  
SG4  
**PLATFORM TO PLATFORM CONNECTION**  
SCALE: 1 : 10

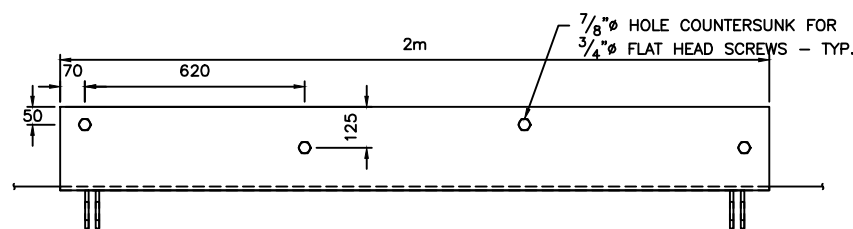

PLAN

**K**  
SG4  
**GANGWAY LANDSIDE CONNECTION - STANDARD DETAIL**  
SCALE: 1 : 10

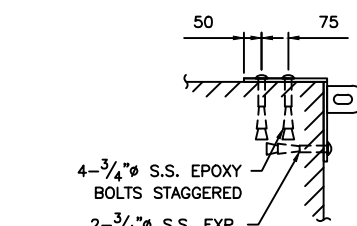

SECTION

Reference Drawings CONSTRUCTION

Structures Section



GENERAL NOTES:

ISSUED FOR: CONSTRUCTION 14/08/01

AMENDMENTS:

NO:	REVISION	APP	DATE:
1	HOOP ORIENTATION	RRB	04/01/02
2	BALLAST	BAP	13/05/02

SCALE: AS NOTED

SURVEY

PREPARED BY: DATE:

DESIGN

PREPARED BY: BAP DATE: 23/05/01  
CHECKED BY: RRB DATE: 23/05/01

DRAWING

PREPARED BY: JSK DATE: 23/05/01  
CHECKED BY: BAP DATE: 23/05/01

APPROVED BY:  
RRB

PROJECT NUMBER:  
61/01/01

PROJECT NAME:

St. GEORGE'S  
REPLACEMENT FERRY PROJEC  
PHASE 1  
DOCK CONSTRUCTION

MARKET WHARF  
St. GEORGE'S PARISH

DRAWING FILE NO: ACAD R-14  
SG-5 Ballasting Plan.dwg

SHEET TITLE:

BALLASTING  
PLAN

SHEET NUMBER: 61/46/01/SG5 REVISION:

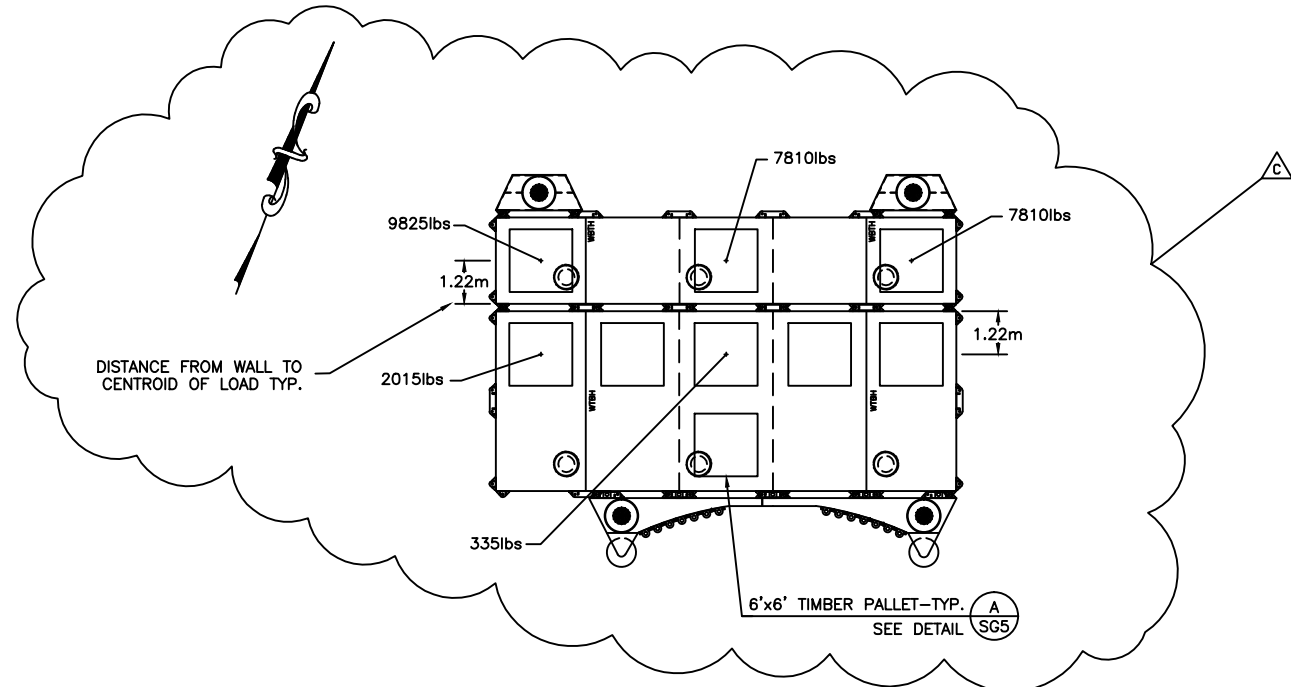

ST. GEORGE'S

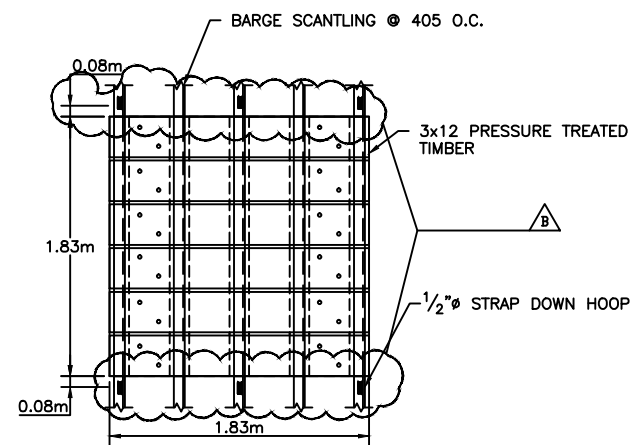

BALLAST PALLET-PLAN

A/SG5

SCALE: 1 : 25

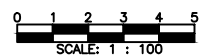

CONSTRUCTION

NOTES:

- BALLAST LOADS ARE SHOWN AT CENTER OF BAY UNLESS NOTED OTHERWISE.
- BALLAST TO BE REMOVEABLE CONCRETE BLOCK OR LEAD.
- BALLAST SHALL BE INSTALLED ON TIMBER PALLETS AT LOCATIONS SHOWN. PALLETS SUPPLIED WITH BARGES.

Reference Drawings